

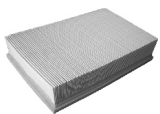

Í N D I C E

P Á G I N A

2	Filtros para Aire - Paneles
6	Filtros para Aire - Línea Japonesa
8	Filtros para Aceite - Unidades Selladas
13	Filtros para Combustible - Unidades Selladas
23	Filtros para Aire
53	Filtros para Freno
54	Filtros para Cabina
55	Filtros Hidráulicos
61	Filtros para Combustible - Cartuchos
64	Filtros para Aceite - Cartuchos
66	Filtros para Aceite - Ecológicos
68	Filtros para Combustible - Ecológicos
69	Cabezales Portafiltros
72	Carcasas Metálicas
75	Carcasas Plásticas
76	Sombretetes y Prefiltros para Aire
79	Accesorios
86	EXTENDERmas
87	UNIPLUG
88	SERIE L1
89	SERIE L2
90	SERIE L
92	LCS2001
93	EMS
94	GC08
95	CAPTOR
96	Kits LANSS

	<p>AP-4050</p> <p>Largo: 277 VW POLO, SEAT TOLEDO DIESEL Ancho: 185 NAFTERO - Nº 120129620AC Alto: 58 Otros:</p>
---	---

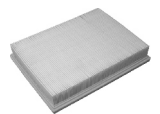
	<p>AP-4060</p> <p>Largo: 250 FORD ESCORT LX - SX - GALAXI 92 Ancho: 192 Alto: 45 Otros:</p>
---	---

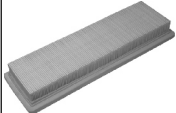
	<p>AP-4051</p> <p>Largo: 341 FIAT FIORINO, DUNA D, SPAZIO D, Ancho: 110 MOTOR 1.3 - Nº 7628911 Alto: 40 Otros:</p>
---	---

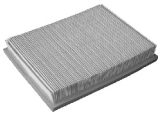
	<p>AP-4061</p> <p>Largo: 250 FIAT PALIO, SIENA DIESEL Y Ancho: 195 NAFTERO 97 - Nº 46420988 Alto: 40 Otros:</p>
---	--

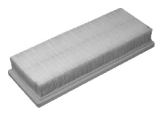
	<p>AP-4052</p> <p>Largo: 302 FIAT DUNA 1.7 DIESEL Ancho: 117 DEL 96 INCLUSIVE - Nº 7634041 Alto: 46 Otros:</p>
---	---

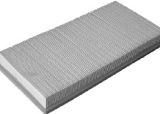
	<p>AP-4062</p> <p>Largo: 403 CHEVROLET SILVERADO DIESEL Y Ancho: 195 NAFTERO Nº 93247344 - 25042558 Alto: 40 Otros:</p>
---	--

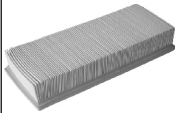
	<p>AP-4053</p> <p>Largo: 335 VW SENDA, SAVEIRO DIESEL, Ancho: 135 TRANSPORTER 1.6 Y 1.7 D Alto: 57 Nº 0261338371-B Otros:</p>
---	---

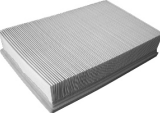
	<p>AP-4063</p> <p>Largo: 260 LAND ROVER DISCOVERY Ancho: 202 AG1103 V 2622 Alto: 58 Otros:</p>
---	---

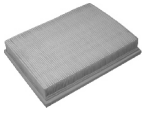
	<p>AP-4054</p> <p>Largo: 215 CHEVROLET CORSA NAF. 1.4 Ancho: 165 CORSA WND - Nº 90411732 Alto: 37 Otros:</p>
---	---

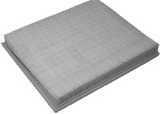
	<p>AP-4064</p> <p>Largo: 286 CHRYSLER JEEP GRAND Ancho: 242 CHEROKEE 4.0 V6, 5.2L V8 Alto: 40 Otros:</p>
---	---

	<p>AP-4055</p> <p>Largo: 380 TRAFIC DIESEL, RENAULT 21 Ancho: 115 NEVADA Alto: 57 Otros:</p>
---	---

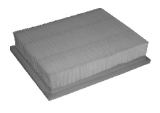
	<p>AP-4065</p> <p>Largo: 269 VW GOLF 1.6i 1.8i 2.0i MEXICO, Ancho: 232 2.0 GTI 16V; 1.9 DIESEL Y Alto: 57 TURBODIESEL Otros:</p>
---	--

	<p>AP-4056</p> <p>Largo: 245 FIAT UNO TURBO DIESEL 1,3 Ancho: 163 Alto: 37 Otros:</p>
---	---

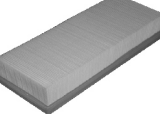
	<p>AP-4066</p> <p>Largo: 370 FORD MONDEO 1.8 TURBODIESEL, Ancho: 150 DTD 95 Alto: 57 Otros:</p>
---	--

	<p>AP-4057</p> <p>Largo: 299 PEUGEOT 405 1,8, 2,0 SRI, Ancho: 102 306 SR, XTI, CABRIOLET 1,8, 2,0L Alto: 49 CITROEN XANTIA 1,8 NAF. Otros:</p>
---	--

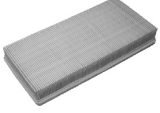
	<p>AP-4067</p> <p>Largo: 296 CHEVROLET BLAZER Ancho: 155 S10 4,32L, V6, GM 2.2LEFI Alto: 42 Nº 25098459 Otros:</p>
---	--

	<p>AP-4058</p> <p>Largo: 297 RENAULT TWINGO Nº 7701036270 Ancho: 88 EXPRESS Alto: 42 Otros:</p>
---	--

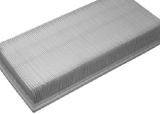
	<p>AP-4068</p> <p>Largo: 318 FORD TRANSIT TURBODIESEL Ancho: 150 Nº 96 VB-960IHA Alto: 58 Otros:</p>
---	---

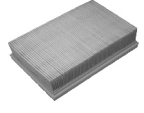
	<p>AP-4059</p> <p>Largo: 201 FORD FIESTA DIESEL 1.8 Ancho: 140 HASTA EL 96 INCLUSIVE Alto: 45 Nº 94FF9601 AA Otros:</p>
---	---

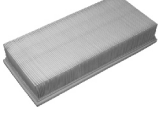
	<p>AP-4069</p> <p>Largo: 276 CHRYSLER SPIRIT, Ancho: 135 CARAVAN 3.0L V6 Alto: 38 Nº 4241042-4342800 Otros:</p>
---	---

AP

	AP-4070 Largo: 341 CHRYSLER JEEP CHEROKEE 2.5L Ancho: 168 4.0L; 6 CILINDROS LAREDO Alto: 40 Otros:		AP-4080 Largo: 380 MUSSO DIESEL C/MOTOR Ancho: 171 5 CILINDROS Alto: 51 Otros:
	AP-4071 Largo: 270 BMW 320; 525C; 528E; 525I Ancho: 150 Alto: 58 Otros:		AP-4081 Largo: 591 MERCEDES BENZ 609D / 709D Ancho: 170 809D (6 CILINDROS) 710 Alto: 51 Otros:
	AP-4072 Largo: 275 KIA SPORTAGE DIESEL Ancho: 200 N° 0K017-13-Z40 Alto: 58 Otros:		AP-4082 Largo: 270 LAND ROVER 114 - 214 Ancho: 108 220 - 414 - 420 Alto: 58 Otros:
	AP-4073 Largo: 288 FIAT DUNA, FIORINO, Ancho: 135 UNO C/MOTOR 1,7 '97 DIESEL Alto: 45 Otros:		AP-4083 Largo: 320 RENAULT LAGUNA 1.8 Ancho: 101 INV./2.0 INV,95 Alto: 57 Otros:
	AP-4074 Largo: 210 CHEVROLET CORSA DIESEL Ancho: 165 N° 8345856L04D, COMBO Alto: 57 Otros:		AP-4084 Largo: 285 VW GOL MI 1.6 - 1.8 - 2.0, Ancho: 162 GOL AB9, GOL GTI Alto: 48 Otros:
	AP-4075 Largo: 325 PEUGEOT 405 DIESEL / SR/SRI Ancho: 156 GL/GLD/GRD DIESEL T Alto: 57 CITROEN /BX 19GTI-TRI/BX19RD Otros: TRD DIESELEVACION VSX TURBO		AP-4084/1 Largo: 285 VW GOL MI 1,6 - 1.8 - 2.0, Ancho: 162 GOL AB9, GOL GTI (C/ESPONJA) Alto: 48 Otros:
	AP-4076 Largo: 320 MERCEDES BENZ SPRINTER Ancho: 275 CON PRE-FILTRO 2.5 310D Alto: 69 Otros:		AP-4085 Largo: 286 FORD K - FIESTA CLX,1.3 I Ancho: 155 Alto: 48 Otros:
	AP-4077 Largo: 257 FORD ESCORT '97 EN Ancho: 183 ADELANTE MOTORES 1.8 Alto: 57 (ORION) DIESEL /T Otros:		AP-4086 Largo: 266 VW TRANSPORTER 2,4 DIESEL 96 Ancho: 218 Alto: 57 Otros:
	AP-4078 Largo: 225 FORD RANGER Ancho: 195 Alto: 57 Otros:		AP-4087 Largo: 340 GM OPEL VECTRA 16V/97 Ancho: 204 CHEV S 10-2.5 Alto: 42 Otros:
	AP-4079 Largo: 287 M. B. 190 D / KORANDO Ancho: 170 C/MOTOR MERCEDES BENZ Alto: 51 (SANYON) Otros:		AP-4088 Largo: 310 PEUGEOT 306 1.8 - 1.6 Ancho: 173-120 Alto: 58 Otros:

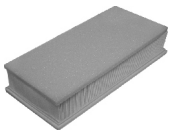
	<p>AP-4089</p> <p>Largo: 325 PEUGEOT 406 ST/SV NAFTERO-STDT Ancho: 156 DIESEL-SVTD DIESEL CON PRE-FILTRO Alto: 67 Otros:</p>
---	---

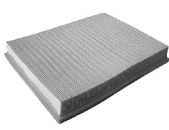
	<p>AP-4099</p> <p>Largo: 293 CHEVROLET ASTRA (NAFTA) Ancho: 237 TODOS (90531003) Alto: 42 Otros:</p>
---	---

	<p>AP-4090</p> <p>Largo: 235 FIAT TIPO / UNO - 705 Ancho: 86 TEMPRA 1.6 Alto: 48 Otros:</p>
---	--

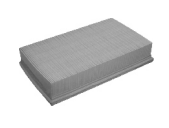
	<p>AP-4100</p> <p>Largo: 211 PEUGEOT 206 TDI (DIESEL) Ancho: 171 Alto: 58 Otros:</p>
---	--

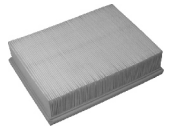
	<p>AP-4091</p> <p>Largo: 244 GM VECTRA DIESEL 2.0 Ancho: 188 Alto: 59 Otros:</p>
---	--

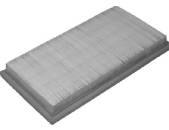
	<p>AP-4101</p> <p>Largo: 329 FORD F100 AMERICA NAFTERA Ancho: 151 BRONCO V8 Alto: 43 Otros:</p>
---	--

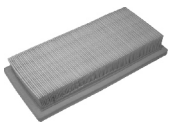
	<p>AP-4092</p> <p>Largo: 310 TOYOTA CELICA - DAIHATSU Ancho: 155 Alto: 48 Otros:</p>
---	--

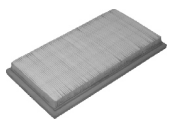
	<p>AP-4102</p> <p>Largo: 285 FORD EXPLORER Ancho: 160 Alto: 32 Otros:</p>
---	---

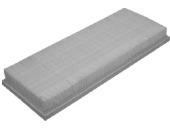
	<p>AP-4093</p> <p>Largo: 400 FORD MONDEO 1.6 - 1.8 Ancho: 150 2.0 16V IE Alto: 41 Otros:</p>
---	---

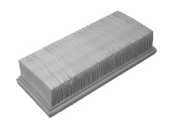
	<p>AP-4103</p> <p>Largo: 275 ROVER 416/420 Ancho: 117 MOTOR 2 LTS. Y 1.2 Alto: 58 Otros:</p>
---	---

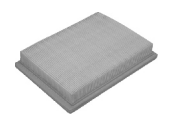
	<p>AP-4094</p> <p>Largo: 223 HONDA CIVIC 1.3 - 1.4 - 1.5 Ancho: 165 PRELUDE Alto: 32 Otros:</p>
---	--

	<p>AP-4104</p> <p>Largo: 310 GM-ASTRA NAFTERO /DIESEL Ancho: 231 Alto: 32 Otros:</p>
---	--

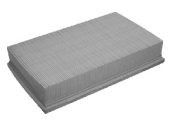
	<p>AP-4095</p> <p>Largo: 310 VW GOLF - PASSAT - POLO Ancho: 184 Alto: 57 Otros:</p>
---	---

	<p>AP-4105</p> <p>Largo: 248 PEUGEOT 307 1.4/1.6-2.0 16V Ancho: 170 Alto: 50 Otros:</p>
---	---

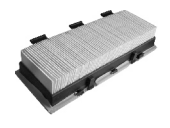
	<p>AP-4096</p> <p>Largo: 266 RENAULT KANGOO RL - 1.4 DIESEL Ancho: 104 Alto: 62 Otros:</p>
---	--

	<p>AP-4106</p> <p>Largo: 301 FIAT -UNO 1.7 DIESEL Ancho: 158 Alto: 34 Otros:</p>
---	--

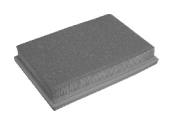
	<p>AP-4097</p> <p>Largo: 234 CHEROKEE 2.5 LUMINA 3.4 2V-6 Ancho: 160 Alto: 47 Otros:</p>
---	--

	<p>AP-4107</p> <p>Largo: 248 PEUGEOT 307 2.0 HDI 1444W6 Ancho: 170 Alto: 64+20 Otros:</p>
---	---

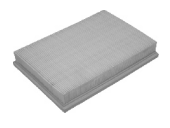
	<p>AP-4098</p> <p>Largo: 256 FORD FIESTA / ORION 1.3i Ancho: 178 (D. '97) - COURIER Alto: 38 Otros:</p>
---	--

	<p>AP-4108</p> <p>Largo: 296 FORD FIESTA DIESEL 2002, Ancho: 140 ECO ESPORT DIESEL, Alto: 48 CITROEN C3 HDI Otros:</p>
---	--

	<p>BA-121</p> <p>Øext.: 181 Øint.: 84 H.: 144 Otros:</p>	<p>TOYOTA DYNA 3000 DIESEL N° 17801-58010 DAIHATSU DELT.</p>
---	---	--

	<p>BA-326/1</p> <p>Øext.: 225 - 245 Øint.: 12 - 148 H.: 129 Otros:</p>	<p>MITSUBISHI CANTER HASTA 95" N° MB120108</p>
---	---	--

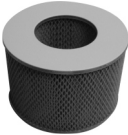
	<p>BA-156</p> <p>Øext.: 220 Øint.: 108 H.: 145 Otros:</p>	<p>TOYOTA LAND CRUISER 4.2 DIESEL TOYOTA COASTER STD N° 17801-68020</p>
---	--	---

	<p>BA-339</p> <p>Øext.: 152 - 245 Øint.: 74 - 164 H.: 135 Otros:</p>	<p>MITSUBISHI PROTON MITSUBISHI MONTERO 2.8 TDI N° MD603384</p>
---	---	---

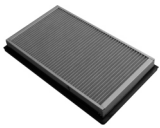
	<p>BA-228/1</p> <p>Largo: 280 Ancho: 166 Alto: 35 Otros:</p>	<p>NISSAN MAXIMA PATHFINDER V 8i SENTRA D - SUNNY LEGACY N° 16546-V0100</p>
---	---	---

	<p>BA-379</p> <p>Øext.: 250 - 330 Øint.: 150 - 250 H.: 50 Otros:</p>	<p>MITSUBISHI SPACE GALANT 2.0 N° MD604952</p>
---	---	--

	<p>BA-233</p> <p>Øext.: 168 Øint.: 80 H.: 140 Otros:</p>	<p>ISUZU TROOPER 3.0 N° 16546-51N01</p>
---	---	---

	<p>BA-384</p> <p>Øext.: 172 - 205 Øint.: 110 - 134 H.: 170 Otros:</p>	<p>MITSUBISHI ACCENT 1.5 MITSUBISHI ECLIPSE N° MD603932</p>
---	--	---

	<p>BA-267</p> <p>Øext.: 133 Øint.: 0 - 72 H.: 280 Otros:</p>	<p>NISSAN PATROL 2.8 D/TD 10 N° 16546-06N00</p>
--	---	---

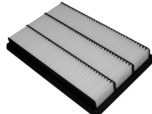
	<p>BA-387</p> <p>Largo: 361,5 Ancho: 237 Alto: 51,5 Otros:</p>	<p>MITSUBISHI MONTERO 3.2 TD N° MR404847</p>
---	---	--

	<p>BA-269</p> <p>Øext.: 127 Øint.: 10 - 70 H.: 170 Otros:</p>	<p>NISSAN PATHFINDER 3.2 TERRANO II 3.2 D N° 16546-04N00</p>
---	--	--

	<p>BA-389</p> <p>Øext.: 172 - 205 Øint.: 110 - 134 H.: 170 Otros:</p>	<p>SPACE WAGON MITSUBISHI COLT/GALANT 1.80 N° MD620385</p>
---	--	--

	<p>BA-297</p> <p>Øext.: 280 Øint.: H.: 40 Otros:</p>	<p>NISSAN SENTRA N° 16546-77A10</p>
---	---	---

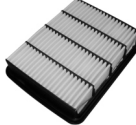
	<p>BA-484</p> <p>Largo: 248 Ancho: 200 Alto: 50 Otros:</p>	<p>MITSUBISHI SPACE WAGON 2.4 N° WL81-13-240 MAZDA PICK UP B 2500-2900 N° MR-266849</p>
---	---	---

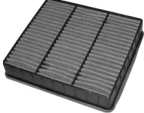
	<p>BA-304</p> <p>Largo: 219 Ancho: 200 Alto: 43 Otros:</p>	<p>MITSUBISHI COLT. LANCER 1.6 98" PROTON 416 G x LI N° MD620737</p>
---	---	--

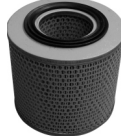
	<p>BA-S01</p> <p>Øext.: 170 Øint.: 78 H.: 148 Otros:</p>	<p>SAANG YONG KORANDO FAMILY N° 23150-01000</p>
---	---	---

	<p>BA-309</p> <p>Largo: 232 Ancho: 186 Alto: 53 Otros:</p>	<p>MITSUBISHI ECLIPSE GALANT 2.0 RUNNER MITSUBISHI SPACE WAGON 2.0 i 16 V N° MB906051</p>
---	---	---

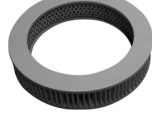
	<p>BA-510</p> <p>Øext.: 260 Øint.: 195 H.: 50 Otros:</p>	<p>HYUNDAI EXCEL GLS 1.5 MITSUBISHI LANCER GLW x 1.4 N° 17220-671-000</p>
---	---	---

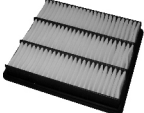
	<p>BA-318</p> <p>Largo: 221 Ancho: 220 Alto: 45 Otros:</p>	<p>MITSUBISHI MONTERO 3.5 V 6 HASTA 99" N° MD620837</p>
---	---	---

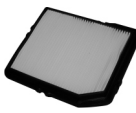
	<p>BA-530</p> <p>Largo: 198 Ancho: 170 Alto: 38 Otros:</p>	<p>HONDA CRX N° 17220-PM7-000</p>
---	---	---------------------------------------

BA

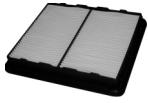

BA-547

Largo: 205 HONDA CIVIC 92-95 INYECCION
 Ancho: 185 N° 17220-PO7-000
 Alto: 43 ROVER 416 AUTOM. 1.6
 Otros:



BA-772

Øext.: 270 ISUZU RODEO - AMIGO 2.6
 Øint.: N° 4310005/8-94465-656-0
 H.: 71
 Otros:

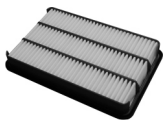

BA-774

Largo: 310 ISUZU AMIGO 3.6 RODEO
 Ancho: 200 HONDA PASSPORT.
 Alto: 52 N° 8-97035-303-0
 Otros: ACURA HONDA N° 17801-0W010



BA-932

Øext.: 243,5 SUZUKI SWIFT 1.3 GLX
 Øint.: N° 13780-62B00
 H.: 36,5
 Otros:

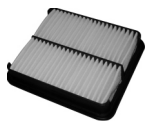

BA-935

Largo: 230 SUZUKI - CHEVROLET
 Ancho: 201 GRAND VITARA 2.0 i - TD
 Alto: 55 N° 13780-77E00
 Otros:



BA-D02

Øext.: 230 DAEWOO TICO
 Øint.: N° 13780A78B00-000
 H.: 27
 Otros:



BA-D10

Largo: 256 DAEWOO LEGANZA 2000 i 16 V
 Ancho: 223 N° 96351225
 Alto: 34
 Otros:

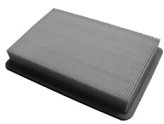

BA-H23

Largo: 255 HYUNDAI ATOS
 Ancho: 178 N° 28113-23001/23100
 Alto: 40
 Otros:



BA-K02

Øext.: 216 KIA BESTA DIESEL
 Øint.: 96 N° K790-23-603B
 H.: 140
 Otros:

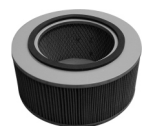

BA-K40

Øext.: 225 ASIA TOPIC 1456-23-603
 Øint.: 13 - 130 AA70A-23-603A
 H.: 95
 Otros:



BL-2080
 Øext.: 97 FORD 14000 MOTOR MWM4
 Øint.: 1"x12 UNF
 H.: 203
 Otros: válv. anti retorno/válv. by-pass



BL-2090
 Øext.: 93 SCANIA 542483 - 173171
 Øint.: 3/4"x16 UNF 807180 - DODGE
 H.: 96 FIAT FIORINO 1.7D 0.5/ 2007
 Otros: válv. anti retorno/válv. by-pass



BL-2081
 Øext.: 97 PERKINS 004115
 Øint.: 3/4"x16 UNF
 H.: 121
 Otros: válv. anti retorno/válv. by-pass



BL-2091
 Øext.: 97 ZANELLO 11150016 Z
 Øint.: M 22x1,5
 H.: 137
 Otros: válv. anti retorno/válv. by-pass



BL-2082
 Øext.: 97 MOTOR 4MWM - CAT. 9L-9200
 Øint.: 1"x12 UNF
 H.: 138
 Otros: válv. anti retorno/válv. by-pass



BL-2092
 Øext.: 97 ZANELLO MOTOR W 56 - W 86
 Øint.: M 22x1,5 UN 960
 H.: 202
 Otros: válv. by-pass



BL-2083
 Øext.: 97 PERKINS 004125 / 2654407
 Øint.: 3/4"x16 UNF JCB 02-100073
 H.: 185
 Otros: válv. anti retorno/válv. by-pass



BL-2094
 Øext.: 110 CAT. 2P4004 - ZANELLO
 Øint.: 1 1/8"x16 UNF SCANIA 1347726
 H.: 262 RENAULT 5000133555
 Otros: 5001846641



BL-2084
 Øext.: 97 J. DEERE ORIG. AR 58956
 Øint.: 13/16"x16 UNF AJ 52400
 H.: 138
 Otros: válv. by-pass



BL-2095
 Øext.: 97 FORD-CASE-INTERNACIONAL
 Øint.: 3/4"x16 TOYOTA - ALLIS CHALMERS
 H.: 133
 Otros: válv. anti retorno/válv. by-pass



BL-2085
 Øext.: 97 DEUTZ ORIGINAL 3002261
 Øint.: 1"x12 UNF VOLVO 3831236
 H.: 203
 Otros: válv. anti retorno/válv. by-pass



BL-2096
 Øext.: 97 DEUTZ 3008001
 Øint.: 1"x12
 H.: 96
 Otros: válv. anti retorno/válv. by-pass



BL-2086
 Øext.: 110 FIAT 150 TURBO
 Øint.: 3/4"x16 UNF ORIG. N° 1901602
 H.: 143
 Otros: válv. anti retorno/válv. by-pass



BL-2097
 Øext.: 110 VALMET - AGCO 836647133
 Øint.: M 24x1,5
 H.: 146
 Otros: válv. anti retorno/válv. by-pass



BL-2087
 Øext.: 110 FIAT ORIGINAL
 Øint.: 1"x12 UNF 4667339/1901604
 H.: 232
 Otros: válv. anti retorno/válv. by-pass



BL-2098
 Øext.: 92 FORD TRANSIT 6203136
 Øint.: M 22x1,5 FOCUS DIESEL
 H.: 94
 Otros: válv. anti retorno/válv. by-pass



BL-2088
 Øext.: 110 DEUTZ ORIGINAL
 Øint.: 1 1/8"x16 UNF 1164406 - 4305722
 H.: 263
 Otros: válv. anti retorno/válv. by-pass



BL-2099
 Øext.: 80 RENAULT 19 RN
 Øint.: M 20x1,5
 H.: 72
 Otros: válv. anti retorno/válv. by-pass























BL-2089
 Øext.: 110 FIAT ORIGINAL 8308721
 Øint.: 3/4"x16 UNF 8822645/ FIAT 673
 H.: 181
 Otros: válv. anti retorno/válv. by-pass



BL-2100
 Øext.: 92 MIT. L200 / KIA PEUGEOT
 Øint.: M 26x1,5 MONTERO DIESEL
 H.: 137 LAND ROVER
 Otros: válv. anti retorno/válv. by-pass

BL

	<p>BL-2101</p> <p>Øext.: 76 LOMBARDINI Øint.: M 12x1,5 H.: 87 Otros: válv. anti retorno/válv. by-pass</p>
	<p>BL-2102</p> <p>Øext.: 76 GM - MITSUBISHI - MAZDA Øint.: M 20x1,5 ISUZU - HONDA - CORSA H.: 78 PEUGEOT 405SR,205 - CHEV. Otros: válv. by-pass</p>
	<p>BL-2103</p> <p>Øext.: 97 ISUZU 5132110180 DIESEL - LUV Øint.: M 20x1,5 CHEVROLET 1980/83 H.: 107 Otros: válv. anti retorno/válv. by-pass</p>
	<p>BL-2104</p> <p>Øext.: 76 LOMBARDINI Nº 270.2175.28 Øint.: M 14x1,5 H.: 76 Otros: válv. anti retorno/válv. by-pass</p>
	<p>BL-2105</p> <p>Øext.: 110 FORD TRACTORES (1959) Øint.: 3/4"x16 ALFA ROMEO - FIAT (1969/70) H.: 96 FIAT TIPO DIESEL - SIENA PALIO DIESEL Otros: válv. anti retorno/válv. by-pass</p>
	<p>BL-2106</p> <p>Øext.: 97 PEUGEOT 504-505 - DODGE (1991/1992) Øint.: M 20 X 1,5 KIA BESTA - R 18 - 2000 D H.: 94 VW TRANSPORTER 2.4 - TRAFIC Otros: válv. anti retorno/válv. by-pass</p>
	<p>BL-2107</p> <p>Øext.: 97 RENAULT 7701348440- R 12 Øint.: 3/4"x16 H.: 75 Otros: válv. anti retorno/válv. by-pass</p>
	<p>BL-2108</p> <p>Øext.: 76 PEUGEOT 205 D G- Rg3 Øint.: M 20x1,5 PEUGEOT 206 1.6 H.: 85 306 XRD / 405 Otros: válv. anti retorno/válv. by-pass</p>
	<p>BL-2109</p> <p>Øext.: 97 AUTOLEVADOR HALLA HDF-30 Øint.: M 20x1,5 MOTOR KIA 3000 H.: 138 Otros: válv. anti retorno/válv. by-pass</p>
	<p>BL-2110</p> <p>Øext.: 92 FIAT SUPER EUROPA - FIAT 147 (TODOS) - BRIO - SPAZIO 1.3 Cl y TR - DUNA DESDE 98 - REGATTA 85 y WEEKEND UNO C/MOTOR 997 FIRE - VIVACE - RENAULT 4 R6-R9-R11-R11 TURBO (72-75) - R12 (72-75) - R12L TL - GTL BREAK HASTA EL 89 - R12 Y5-G15 - ALPINE - BREAK R18 GTL C/MOTOR 1.4 HASTA 89 - TRAFIC 1.4 HASTA 89 H.: 62 Otros: válv. anti ret./válv. by-pass</p>
	<p>BL-2111</p> <p>Øext.: 90 LAND ROVER DISCOVERY Øint.: 13/16"x16 (ERR-5542) H.: 80 Otros: válv. by-pass</p>
	<p>BL-2112</p> <p>Øext.: 75 AMERICAN MOTORS (1983-86) Øint.: 13/16"x16 GM (1975-77) - GM 25010633 H.: 88 JEEP (1983-86) Otros: válv. anti retorno/válv. by-pass</p>
	<p>BL-2113</p> <p>Øext.: 79 BMW 11421250534 - SUZUKI Øint.: 3/4"x16 TOYOTA - GMC - BOBCAT 6665603 H.: 87 Otros: válv. anti retorno/válv. by-pass</p>
	<p>BL-2114</p> <p>Øext.: 75 VW - GACEL - SENDA Øint.: 3/4"x16 AUDI - FORD - NISSAN H.: 121 Otros: válv. anti retorno/válv. by-pass</p>
	<p>BL-2115</p> <p>Øext.: 94 CATERPILLAR - CUMMINS Øint.: 1"x16 3903224 - 3908616 H.: 137 Otros:</p>
	<p>BL-2116</p> <p>Øext.: 97 CONSOLIDATED DIESEL Øint.: 1"x16 CUMMINS - 3903964 - 3932217 H.: 182 CASE J 903264 Otros: válv. anti retorno</p>
	<p>BL-2117</p> <p>Øext.: 95 CASE INT. 3132737 R93 Øint.: 1"x12 NEW HOLLAND 81879134 H.: 182 IHC 398080 R2 - DEUTZ 0300-2261 Otros: válv. anti retorno/válv. by-pass</p>
	<p>BL-2118</p> <p>Øext.: 96 CHEVROLET Øint.: 13/16"x16 GM 2642084 - 2642344 H.: 138 Otros:</p>
	<p>BL-2119</p> <p>Øext.: 109 MERCEDES BENZ 003-184-33-01 Øint.: 1"x12 H.: 182 Otros:</p>
	<p>BL-2120</p> <p>Øext.: 119 CASE J9-19562 Øint.: 2 1/4"x12 FULL FLOW / BY PASS H.: 245 Otros:</p>



BL-2121

Øext.: 94
Øint.: M 26x1,5
H.: 125
Otros: válv. anti retorno/válv. by-pass

ISUZU PICK UP 3.1
TROOPER-SUZUKI 16510-78-E00
DAIHATSU 15601-87308
8-94360-427-0 RFY0-14-302 RF71-14-302



BL-2132

Øext.: 97
Øint.: 3/4"x16
H.: 140
Otros: válv. anti retorno/válv. by-pass

TOYOTA HiLux y HiAce Diesel,
LANDCRUISER, 4 RUNNER, DYNA.
15600-41010 / 15600-61030
15600-87320 / 1560A-41010



BL-2122

Øext.: 110
Øint.: 3/4"x16
H.: 145
Otros: válv. anti retorno/válv. by-pass

FIAT IVECO 1902076 - 1907582
5983900 - 1902628 - 1903628



BL-2133

Øext.: 125
Øint.: M 36x1,5
H.: 220
Otros:

NISSAN 15201-29009 MITSUBISHI
ME 074013-ME 074235
CATERPILLAR DP80



BL-2123

Øext.: 95
Øint.: M 20x1,5
H.: 80
Otros: válv. anti retorno/válv. by-pass

PEUGEOT 405 / MAZDA / MITSUBISHI
M030795 / CLARK
J. DEERE M801209 / HYUNDAI
MITSUBISHI (AUTOELEVADORES Y CAMIONES)



BL-2134

Øext.: 68
Øint.: M 20x1,5
H.: 75
Otros: válv. anti retorno/válv. by-pass

GM 12582255 / 90541162 / 94314263
CORSA DE 1.7 HASTA 1997
FIAT 46751179 / SIENA - PALIO



BL-2125

Øext.: 110
Øint.: M 30x2
H.: 212
Otros: válv. anti retorno/válv. by-pass

FIAT EUROTECH - ASTRA 6438 - IVECO 190.33
EUROTRAKKER 190E-30-34 / 1903629
190-33-190-33N-1930542 / 1930906
/N° ORIG. 1930542 / 1930906



BL-2135

Øext.: 75
Øint.: 3/4"x16
H.: 95
Otros: válv. anti retorno/válv. by-pass

TOYOTA CAMRI - SUPRA 90915-03005
CHRYSLER 4105409 - FIAT



BL-2126

Øext.: 97
Øint.: 1 1/2"x16 UNF
H.: 138
Otros: válv. by-pass

J. DEERE RE-59754



BL-2136

Øext.: 80
Øint.: 3/4" X 16
H.: 100
Otros: válv. anti retorno/válv. by-pass

TOYOTA 15-601-13010
GM 94463715 - SUZUKI



BL-2127

Øext.: 110
Øint.: 1 1/8"x16 UNF
H.: 147
Otros:

CATERPILLAR 9N-6007



BL-2137

Øext.: 104
Øint.: M 24x1,5
H.: 127
Otros: válv. anti retorno/válv. by-pass

TOYOTA 90915-03006 - 90915-30002
LAND CRUISER 4.2 SW
3.0TD COASTER



BL-2128

Øext.: 110
Øint.: 1"x12
H.: 100
Otros: válv. anti retorno/válv. by-pass

MIT. 32A4000100 / CAT. 1039737



BL-2138

Øext.: 104
Øint.: M 26x1,5
H.: 152
Otros: válv. anti retorno/válv. by-pass

TOYOTA 15601-78010 - DYNA



BL-2129

Øext.: 110
Øint.: 1"x12
H.: 162
Otros: válv. anti retorno/válv. by-pass

ISUZU 8-94321219-1
MITSUBISHI 32B4000100
YALE 778000204-910095897



BL-2139

Øext.: 104
Øint.: M 26x1,5
H.: 125
Otros: válv. anti retorno/válv. by-pass

MITSUBISHI M069782
MOTORCRAFT E5T2 - 6731A
HYUNDAI 26300-42010 (H 100)
NISSAN VS11-14302 / VSY1-14302
(DOBLE FILTRACION)



BL-2130

Øext.: 97
Øint.: M 20x1,5
H.: 71
Otros: válv. anti retorno/válv. by-pass

AMC - 8983501900
CHRYSLER 4186267
MAZDA - MITSUBISHI



BL-2140

Øext.: 104
Øint.: M 26x1,5
H.: 150
Otros: válv. anti retorno/válv. by-pass

MITSUBISHI ME-013307-013343
MONTERO



BL-2131

Øext.: 140
Øint.: 1 1/2"x16
H.: 95
Otros: válv. anti retorno/válv. by-pass

SILVERADO ORIGINAL
GM-MSB-74001



BL-2141

Øext.: 70
Øint.: M 20x1,5
H.: 87
Otros: válv. anti retorno/válv. by-pass

MAZDA JERO 14-302
GM CORSA 1.7 DIESEL
FIAT PALIO - HONDA PRELUDE
MITSUBISHI SPACE WAGON
SIENA EX - EXL

BL

	BL-2142 Øext.: 80 DAIHATSU 15601-87103 CUORE 600 Øint.: 3/4"x16 CHARADE - DAEWO TICO H.: 70 SUZUKI 16510-60 B-10 Otros: válv. anti retorno/válv. by-pass
	BL-2143 Øext.: 65 DAIHATSU 15601-87204 Øint.: 3/4"x16 CHARADE APLAUSE H.: 70 TOYOTA 90915-03001 COROLLA 160-180 TERCEL RAV4 Otros: válv. anti retorno/válv. by-pass
	BL-2144 Øext.: 82 MAZDA HE-19-23-802 / 8173-23-802 Øint.: M 20x1,5 FORD D872-6731A H.: 102 HONDA MOTORES KUBOTA Otros: válv. anti retorno/válv. by-pass
	BL-2145 Øext.: 122 CHEVROLET CAMION Øint.: 1 1/2"x12 UNF FRONTAL ISUZU NPR 4.3 H.: 120 ISUZU 8-97148270-0 Otros: válv. by-pass
	BL-2146 Øext.: 104 ISUZU 8-94114-585-0 Øint.: M 20x1,5 MAZDA 5201-23-810A H.: 82 NISSAN 15208-HC-310 MAZDA 2200 - KIA BESTA / SPORTAGE Otros: válv. anti retorno/válv. by-pass
	BL-2147 Øext.: 72 KIA OB-631-14-302 ASIA TOPIC Øint.: M 20x1,5 SUBARU JUSTY 15208-KA000/10 H.: 65 Otros: válv. anti retorno/válv. by-pass
	BL-2148 Øext.: 104 ME-014833 MITSUBISHI MOTORES. Øint.: M 20x1,5 H.: 125 Otros: válv. anti retorno/válv. by-pass
	BL-2149 Øext.: 94 KIA PREGGIO DIESEL Øint.: M 20x1,5 KIA ASIA K 800-23-802 H.: 170 1302-23-802N - K 631-14-300 Otros: válv. anti retorno/válv. by-pass
	BL-2150 Øext.: 110 TERMOKING 11-3871 Øint.: 1"x12 UNF H.: 183 Otros:
	BL-2151 Øext.: 94 FORD RANGER CLARK CY80 Øint.: 3/4"x16 LINDE SERIL H10/SERIL H20, SEAT H.: 140 1.9TDI SE 93, CORDOBA 1.9 VW GOL 1.9D/1.9SD, PASSATI 1.9 TDI POLO III 1.9TDI, SAVEIRO1.6/1.9D, TRANSF Otros: válv. anti retorno/válv. by-pass
	BL-2152 Øext.: 79 TOYOTA 3000 ORIG.909192-0003 Øint.: 3/4"x16 90915-TB 001-909152001 H.: 87 J. DEERE 300 SERIE DENSO 1150104960 Otros: válv. anti retorno/válv. by-pass
	BL-2153 Øext.: 94 IVECO 2992242 Øint.: M 27x2 EUROARGO 170 E22 H.: 173 CUMMINS 4897898 Otros: CNH 87803260
	BL-2154 Øext.: 97 AGCO 4226293M1 Øint.: M 24x1,5 PERKINS 2654A111 H.: 202 CATERPILLAR 1269-8325 Otros: válv. anti retorno/válv. by-pass
	BL-2155 Øext.: 108 VOLVO 477556, 4775556-5, Øint.: 1 3/8"x16 471392, 471392-1 H.: 264 CUMMINS 3304232 VER Otros: válv. by-pass
	BL-2156 Øext.: 97 IVECO 2995655 Øint.: M 22x1,5 FURGON DAILY H.: 143 Otros: válv. anti retorno/válv. by-pass
	BL-2157 Øext.: 110 SCANIA 1347726 / 1117285 Øint.: 1"1/8x16 UNF 562810 - VOLVO PENTA H.: 262 VOLVO TRUCKS Otros:
	BL-2158 Øext.: 97 KOMATSU Øint.: 1"x16 DAEWOO 65055105015 H.: 180 Otros: válv. anti retorno
	BL-2159 Øext.: 97 HANOMAG 700 Øint.: M24x2 ORIG. JX 85100C H.: 135 Otros: válv. anti retorno/válv. by-pass
	BL-2160 Øext.: 78 MICHIGAN R25C Øint.: M 20x1,5 R 0010602220036. H.: 123 Otros: válv. anti retorno/válv. by-pass
	BL-2161 Øext.: 110 IVECO EUROTECH Øint.: M 30x2 EUROTRAKER CURSOR H.: 232 STRALIS /2992544/99445200 Otros: CNH 1931099



	<p>BL-2162</p> <p>Øext.: 78 INTERNATIONAL 71185 Øint.: 3/4"x16 FORD RANGER 3.0 H.: 137 Otros: válv. anti retorno/válv. by-pass</p>
	<p>BL-3000</p> <p>Øext.: 119 CUMMINS 3318853 - FORD CARGO Øint.: 2 1/4"x12 FULL FLOW / BY PASS H.: 300 Otros:</p>
	<p>BL-9001</p> <p>Øext.: 119 CUMMINS 2882674 / 3101869 Øint.: M 95 x 2,5 KOMATSU 600 211 1340 H.: 296 HYUNDAI 11NB-70110 Otros: VENTURI</p>
	<p>BL-9009</p> <p>Øext.: 119 CUMMINS 3401544 Øint.: 2 1/4"x12 H.: 300 Otros: VENTURI</p>

BR



BR-1015H

Øext.: 97
 Øint.: 1"x14
 H.: 191
 Otros: M 32x2,5

CUMMINS 38318715
 FORD CARGO 4C459C340BA
 VW 2R0127177D.



BR-1029

Øext.: 88
 Øint.: 38 - 19
 H.: 110
 Otros:

RENAULT TRAFIC CAV 7111/796
 VALMET 81248200
 M. F. 2710806M91



BR-1020P

Øext.: 73
 Øint.: M 16x1,5
 H.: 123
 Otros:

FIAT IVECO - PERKINS 4283
 FORD 14000 MOTOR MWM6
 RGG 127177



BR-1030

Øext.: 97
 Øint.: M 20 X 1,5
 H.: 128
 Otros: M 36 X 1,5

MITSUBISHI MB-220900 L200 - 300 DIESEL
 MAZDA 1456-23570A
 ISUZU 8-94121-431-0
 HYSTER 1334350 - HYUNDAI 31973-44001
 YALE CN 778000201 - MONTERO - KIA



BR-1021

Øext.: 84
 Øint.: 19,1
 H.: 100
 Otros:

DEUTZ ORIGINAL 3009688/3020986



BR-1031

Øext.: 88
 Øint.: 23,9
 H.: 72
 Otros:

DEUTZ ORIGINAL 3009689



BR-1022

Øext.: 110
 Øint.: 3/4"x16 UNF
 H.: 180
 Otros:

FIAT ORIGINAL 4618310
 IVECO 1901605



BR-1032

Øext.: 88
 Øint.: 7/8"x14
 H.: 175
 Otros:

CATERPILLAR 1R-0751
 6L-4783 / 1R-0759



BR-1023

Øext.: 84
 Øint.: 19,5
 H.: 71
 Otros:

PERKINS 004060
 DEUTZ 3020986 J. DEERE



BR-1033

Øext.: 92
 Øint.: 3/4"x16
 H.: 138
 Otros: M 36x1,5

DAEWOO - ISUZU - MITSUBISHI
 NISSAN - TOYOTA 23390-64480
 TOYOTA 23303-64010 4
 RUNNER 2.5/HI-LUX 2.4



BR-1024

Øext.: 78
 Øint.: M 16x1,5
 H.: 123
 Otros:

SCANIA - DEUTZ 01160243 - FIAT



BR-1034

Øext.: 86
 Øint.: M 16x1,5
 H.: 122
 Otros:

FORD 14.000 (SALIDA DE TANQUE)



BR-1025

Øext.: 84 - 88,5
 Øint.: 24
 H.: 100
 Otros:

DEUTZ 3018134



BR-1035

Øext.: 76
 Øint.: M 16x1,5
 H.: 87
 Otros:

DEUTZ MWM - BOBCAT
 FORD CAMIONES



BR-1026

Øext.: 84
 Øint.: 19,1
 H.: 134
 Otros:

ZANELLO PERKINS 004178



BR-1036P

Øext.: 79
 Øint.: M 16x1,5
 H.: 130
 Otros:

CAV 7176/906 - FIAT - IVECO
 VW - LUCAS 906 ANTIBURBUJA



BR-1027

Øext.: 96
 Øint.: 1"x14 UNF
 H.: 182
 Otros:

CATERPILLAR 1P 2299 - 6L-7440
 KOMATSU



BR-1037

Øext.: 92
 Øint.: 3/4"x16
 H.: 133
 Otros:

NISSAN 16403-05D00



BR-1028

Øext.: 88
 Øint.: 19
 H.: 72
 Otros:





















PERKINS - CAV 7111/296 ROLLED PAPER
 VALMET 836015106



BR-1038

Øext.: 86
 Øint.: M 16x1,5
 H.: 138
 Otros: 3/8W

M.B. SPRINTER 0925505
 MAXION 72104

	<p>BR-1039</p> <p>Øext.: 92 Øint.: M 24x1,5 H.: 135 Otros:</p> <p>SCANIA LINEA SERIE 4, '98 EN ADELANTE 1372444</p>
	<p>BR-1040P</p> <p>Øext.: 94 Øint.: M 14x1,5 H.: 206 Otros:</p> <p>IVECO 1907539 FIAT 1908547</p>
	<p>BR-1041</p> <p>Øext.: 78 Øint.: M 16x1,5 H.: 146 Otros:</p> <p>ASTRA IVECO 1907640 S/PURG. (CAMIÓN)</p>
	<p>BR-1042</p> <p>Øext.: 97 Øint.: 1 1/2"x16 H.: 140 Otros:</p> <p>FILTRO PARA SURTIDOR GIL BARCO R-18189-10</p>
	<p>BR-1043</p> <p>Øext.: 94 Øint.: 3/4"x16 H.: 111 Otros:</p> <p>GM 94051085 ISUZU 1-13240074-0</p>
	<p>BR-1044</p> <p>Øext.: 86 Øint.: 10 - 10 H.: 174 Otros:</p> <p>VW POLO DIESEL ENT. Y SALIDA CRUZADA C/ GRAMPA</p>
	<p>BR-1045</p> <p>Øext.: 90 Øint.: 12,5 H.: 138 Otros:</p> <p>FORD TRANSIT 2.5 (DESDE 97)</p>
	<p>BR-1046P</p> <p>Øext.: 93 Øint.: 1"x12 H.: 230 Otros:</p> <p>KODIAK N° 15618921</p>
	<p>BR-1047P</p> <p>Øext.: 93 Øint.: 1"x14 UNF H.: 230 Otros:</p> <p>CUMMINS N° 3308638</p>
	<p>BR-1048P</p> <p>Øext.: 93 Øint.: 1"x12 H.: 230 Otros:</p> <p>FORD, GMC, ISUZU CAMIONES Y BUSES</p>
	<p>BR-1066P</p> <p>Øext.: 86 Øint.: 10 - 10 H.: 174 Otros:</p> <p>FORD MONDEO, ESCORT 1,8 DIESEL, ORION</p>
	<p>BR-1067</p> <p>Øext.: 93 Øint.: M 20x1,5 H.: 111 Otros:</p> <p>MAZDA S 213-23-570 FORD E3T2-9155B - J. DEERE</p>
	<p>BR-1068</p> <p>Øext.: 76 Øint.: 3/4"x16 H.: 80 Otros:</p> <p>NISSAN 16403-2700 TOYOTA 23303-54071 ISUZU</p>
	<p>BR-1069P</p> <p>Øext.: 93 Øint.: 1"x14 UNF H.: 165 Otros:</p> <p>CUMMINS 3843447 KOMATSU 1304800-H1</p>
	<p>BR-1070P</p> <p>Øext.: 77 Øint.: M 16 X 1,5 H.: 115 Otros:</p> <p>CASE-J 911213 BOBCAT 6667352</p>
	<p>BR-1071P</p> <p>Øext.: 97 Øint.: 1"x14 UNF H.: 203 Otros:</p> <p>CUMMINS 156172 CASE</p>
	<p>BR-1072P</p> <p>Øext.: 96 Øint.: 13/16"x18 H.: 165 Otros:</p> <p>CUMMINS - CONSOLIDATED DIESEL 3925274 - 3930942 - 3903410</p>
	<p>BR-1073</p> <p>Øext.: 73 Øint.: M 16x1,5 H.: 123 Otros:</p> <p>CUMMINS 3903640 DEUTZ AGCO 04020795</p>
	<p>BR-1074P</p> <p>Øext.: 88 Øint.: M 16x1,5 H.: 158 Otros:</p> <p>FIAT 147 DUNA DIESEL SENDA, FORD, RENAULT VW 68127177 - IVECO 1902138</p>
	<p>BR-1075</p> <p>Øext.: 94 Øint.: 1"x14 UNF H.: 267 Otros:</p> <p>CATERPILLAR 1R-0712 4N-5823 / 1R-0749 Alta Eficiencia</p>

BR

	BR-1076 Øext.: 97 Øint.: 1"x12 H.: 204 Otros: GM 5148023 DETROIT TEREX
	BR-1077 Øext.: 97 Øint.: 13/16"x12 H.: 182 Otros: GM 5148171 DETROIT DIESEL
	BR-1078P Øext.: 77 Øint.: M 16x1,5 H.: 143 Otros: CONSOLIDATED DIESEL 3843760
	BR-1079P 1º Øext.: 83 Øint.: 17 H.: 155 Otros: NEW HOLLAND 87840591 (87801341 FLUJO INVERSO) CASE P2950591 PRE-FILTRO.
	BR-1080P 2º Øext.: 83 Øint.: 17 H.: 198 Otros: NEW HOLLAND 87840590 CASE 87802921 - FILTRO FINAL
	BR-1081P 1º Øext.: 83 Øint.: 17 H.: 135 Otros: CATERPILLAR 138-3100 CATERPILLAR 163-4465 (CAT. 151-2409 FLUJO INVERSO) PRE-FILTRO
	BR-1082P 2º Øext.: 83 Øint.: 17 H.: 155 Otros: CATERPILLAR 1383098 - 1005593 1596102 - FILTRO FINAL
	BR-1083P 1º Øext.: 83 Øint.: 17 H.: 198 Otros: JOHN DEERE RE508633 - RE62423 RES8376 - PRE-FILTRO.
	BR-1084P 1º Øext.: 83 Øint.: 17 H.: 155 Otros: JOHN DEERE RE62424 - RE61723 (RE516477 FLUJO INVERSO). PRE-FILTRO.
	BR-1085 Øext.: 128 Øint.: 1 1/2"x16 H.: 282 Otros: FILTRACION DE GRAN CAUDAL P/COMBUSTIBLE UTILIZA CABEZAL CB-5013.
	BR-1086P 2º Øext.: 83 Øint.: 17 H.: 135 Otros: JOHN DEERE RE62418 RE50455 - RE503254 FILTRO FINAL
	BR-1087P 2º Øext.: 83 Øint.: 17 H.: 155 Otros: JOHN DEERE RE53400 - RE62419 RE52987 - FILTRO FINAL.
	BR-1088P 1º Øext.: 83 Øint.: 17 H.: 198 Otros: JOHN DEERE RE65431 (RES08846 FLUJO INVERSO) PRE-FILTRO.
	BR-1089P 1º Øext.: 83 Øint.: 17 H.: 155 Otros: CATERPILLAR 1174089 LIEBHERR 7381646 PRE-FILTRO.
	BR-1090 Øext.: 94 Øint.: 7/8"x14 H.: 267 Otros: CATERPILLAR 1R-0753
	BR-1091P 1º Øext.: 83 Øint.: 17 H.: 155 Otros: CATERPILLAR 1311812 LIEBHERR 7381877 PRE-FILTRO
	BR-1092 Øext.: 88 Øint.: 10 - 10 H.: 175 Otros: FOCUS TURBO DIESEL
	BR-1093P Øext.: 88 Øint.: 8 - 8 H.: 145 Otros: VW POLO CLASSIC 1.9 TDI SEAT CORDOBA 1.9 TDI
	BR-1094P Øext.: 96 Øint.: 3/4"x16 H.: 165 Otros: AGCO - DEUTZ SEPARADOR 04020788
	BR-1095P Øext.: 88 Øint.: 8 - 8 H.: 165 Otros: M 10x1,5 FORD INTERNACIONAL Nº 72121 MODELO NUEVO



BR-1096

Øext.: 88
Øint.: 8 - 8
H.: 157
Otros: M 10x1,5

NISSAN FRONTIER
MODELO 2003/MOTOR
MWM905400150018
BLAZER 2.8 /TS-10



BR-1106

Øext.: 84
Øint.: 19
H.: 113
Otros:

MASSEY FERGUSON 2710806 - M91



BR-1097

Øext.: 76
Øint.: M 20x1,5
H.: 88
Otros:

MAZDA B2200 DIESEL
B2500 DIESEL
AL. CHALM. 2098616



BR-1107P ^{1º}

Øext.: 83
Øint.: 17
H.: 130
Otros:

PRE FILTRO PRIMARIO
SEPARADOR DE AGUA
30 MICRONES
REEM. BR-1081 P



BR-1098

Øext.: 97
Øint.: 1"x14 UNF
H.: 165
Otros:

MOTOR CRAFT FG-762
FORD D3HZ-9365-A



BR-1108P ^{1º}

Øext.: 83
Øint.: 17
H.: 155
Otros:

NEW HOLLAND 87802332
CASE 87802923
(FLUJO INVERSO PRE-FILTRO.)



BR-1099

Øext.: 110
Øint.: 7/8"x14
H.: 203
Otros:

NAVISTAR (IHC) 1809789C1
MOTOR DT 360



BR-1109P ^{1º}

Øext.: 83
Øint.: 17
H.: 198
Otros:

JOHN DEERE RE-509036 / RE-517180
(FLUJO INVERSO PRE-FILTRO)



BR-1100P

Øext.: 97
Øint.: 1"x14 UNF
H.: 248
Otros:

CUMMINS 3889716 / 3329289
FUEL WATER SEPARADOR



BR-1110P ^{2º}

Øext.: 83
Øint.: 17
H.: 198
Otros:

MOTORCRAFT
EFG-184 - 4032667 - 4352681
YCIS-9176-AB
(FLUJO INVERSO FILTRO FINAL)



BR-1101H

Øext.: 97
Øint.: M 20x1,5
H.: 122
Otros: M 32x2,5

DEUTZ - M. FERGUSON
FLUJO INVERSO
(USA CABEZAL CB-5020)



BR-1111H

Øext.: 96
Øint.: 3/4"x16
H.: 122
Otros: M 32x2,5

AGCO -DEUTZ 04024184
(USA CABEZAL CB-5006)
FLUJO NORMAL



BR-1102

Øext.: 97
Øint.: M 16x1,5
H.: 135
Otros:

DEUTZ AGCO 04020794



BR-1112

Øext.: 80
Øint.: 3/4"x16
H.: 173
Otros: M 36x1,5

NISSAN TERRANO H 2.7 TD
PATROL - 16405-0170



BR-1103P

Øext.: 96
Øint.: M 20x1,5
H.: 165
Otros:

SEPARADOR DE AGUA
P/CABEZAL DOBLE CB-5020



BR-1113

Øext.: 90
Øint.: M 20x1,5
H.: 80
Otros:

MINIBISHI CANTER ME-006066
HYUNDAI 31945-41001
CAT. 94-7073



BR-1104P ^{2º}

Øext.: 83
Øint.: 17
H.: 120
Otros:

JOHN DEERE RE 60021/RE 503747
TRACTOR 5210 - 5510 / PERKINS 26560140
LIEBHERR /FILTRO FINAL



BR-1114

Øext.: 80
Øint.: 3/4"x16
H.: 120
Otros: M 10x1,5

NISSAN 16405-V0701
PATROL 3.3 DIESEL
KOMATSU/RGG 127177



BR-1105P ^{1º}

Øext.: 83
Øint.: 17
H.: 155
Otros:

JOHN DEERE RE 53729
RE 62421 (PRE-FILTRO)



BR-1115

Øext.: 92
Øint.: M 20x1,5
H.: 125
Otros:

MAZDA RF-03-23-570 S 213-23-570 -
C/TUBO ANTI-BURBUJA
PAPEL ENROLLADO
REEMP. BR-1067

BR



BR-1116i

Øext.: 62 NISSAN 16400-V2700 MAXIMA 3.0
 Øint.: 8 - 8 SENTRA 1.6
 H.: 125 ISUZU TROOPER 2.6 8941257890
 Otros:



BR-1117i

Øext.: 82 NISSAN 16400-N9600
 Øint.: 8 - 8 FORD 3XY-9155-F
 H.: 122
 Otros:



BR-1118i

Øext.: 72 - 56 MITSUBISHI MB-504756
 Øint.: M 14x1,5 (IN) LANCER - HONDA ACCORD
 M 12x1,25 (OUT) CIVIC
 H.: 120 DAIHATSU CHARADE



BR-1119H

Øext.: 97 VW 2R0127177 - CAMION 17220
 Øint.: 1"x14 FORD FLUJO INVERSO
 H.: 173 (USA CABEZAL CB-5016)
 Otros: M 32x2,5 AGRALE MICROBUS VOLARE
 MWM 4.10TCA / CUMMINS 6 BTAA



BR-1120

Øext.: 110 FIAT IVECO EUROARGO 170 E21
 Øint.: 1"x14 UNF MOTOR MWM-R17-2807
 H.: 147
 Otros:



BR-1121P ^{1º}

Øext.: 87 NEW HOLLAND 87803444
 Øint.: 17 CASE 87803445
 H.: 155 (FLUJO INVERSO)
 Otros: PRE-FILTRO GEN III)



BR-1122P ^{2º}

Øext.: 87 NEW HOLLAND 87803441
 Øint.: 17 CASE 87803442
 H.: 198 (FILTRO FINAL GEN III)
 Otros:



BR-1123P

Øext.: 107 CAT 1335673 / 1290373
 Øint.: 1"x14 UNF RACOR 4120
 H.: 266 J. DEERE RE502203
 Otros: EQUIPOS MARINOS IND.



BR-1124

Øext.: 76 KOMATSU 600-311-8220
 Øint.: 3/4"x16 613-671-6120
 H.: 145
 Otros:



BR-1125P ^{1º}

Øext.: 83 MOTOR AGCO/SISU
 Øint.: 17 N° ORIG. 8368-62600
 H.: 177 VALTRA 20366575
 Otros: (FLUJO INVERSO PRE-FILTRO)



BR-1126P ^{2º}

Øext.: 83 AGCO - SISU N° ORIG. 8368-62602
 Øint.: 17 VALTRA 20366577
 H.: 198 PERKINS 26560141
 Otros: FILTRO FINAL



BR-1127

Øext.: 94 SURTIDOR PRIMARIO
 Øint.: 1"x12
 H.: 138
 Otros:



BR-1129i

Øext.: 62 - 56 MEGANE 2.0 i RT, RXE 97
 Øint.: 8 - 8 TWINGO1.3
 H.: 128 HYUNDAI - DAIHATSU
 Otros:



BR-1130i

Øext.: 62 - 56 FIAT FIORINO -TIPO UNO
 Øint.: 8 - 8
 H.: 164
 Otros:



BR-1131P

Øext.: 83 NEW HOLLAND 47135706
 Øint.: M 16x1,5 IVECO1902138 /VW 68127177
 H.: 165 (REEMP. AL BR-1074)
 Otros: M 8x1,25



BR-1132H

Øext.: 97 BERNARDIN
 Øint.: 3/4"x16 (USA CABEZAL CB-5006)
 H.: 155 FLUJO NORMAL
 Otros: M 32x2,5)



BR-1133P ^{1º}

Øext.: 83 SISU 836859302V
 Øint.: 17 VALTRA 20359302
 H.: 155 (PRE-FILTRO)
 Otros:



BR-1134i

Øext.: 62 - 56 BERLINGO 1.4, 1.6
 Øint.: 8 - 8 PEUGOT PARTNER 307-206
 H.: 137 KANGOO EXPRESS LAGUNA
 Otros:



BR-1135i

Øext.: 62 - 56 GM ORIG.93281612 CORSA
 Øint.: 8 - 8 VECTRA, ASTRA, SEAT CORDOBA,
 H.: 162 PALIO, MERIVA
 Otros:



BR-1136P ^{1º}

Øext.: 83 AGCO 3780299M1 - SISU 836659300V
 Øint.: 17 PERKINS 26560145
 H.: 135 VALTRA 20359300 (PRE-FILTRO)
 Otros:



BR-1137P **1º**
 Øext.: 83 JOHN DEERE RE-509208
 Øint.: 17 (FLUJO INVERSO PRE-FILTRO)
 H.: 155
 Otros:



BR-1148H
 Øext.: 110 RACOR R120A
 Øint.: 1"x14
 H.: 180
 Otros: M 95x2,5



BR-1138P **1º**
 Øext.: 83 CATERPILLAR 100-6374
 Øint.: 17 (PRE-FILTRO)
 H.: 135
 Otros:



BR-1149H
 Øext.: 110 VOLVO 11110668 / 11110474 RK - 120
 Øint.: 1"x14 VW 20741196 CAMION 310
 H.: 218
 Otros: M 95x2,5



BR-1139P **1º**
 Øext.: 83 CATERPILLAR 234-7967
 Øint.: 17 (FLUJO INVERSO PRE-FILTRO)
 H.: 177
 Otros:



BR-1152P **2º**
 Øext.: 83 CATERPILLAR 156-1200/246-0208
 Øint.: 17 FILTRO FINAL
 H.: 135
 Otros:



BR-1140P **1º**
 Øext.: 87 JOHN DEERE RE-526319 / RE-529644
 Øint.: 17 (FLUJO INVERSO PRE-FILTRO GEN III)
 H.: 155
 Otros:



BR-1153P **2º**
 Øext.: 83 VOLVO 11711183 / LIEBHERR 7381645
 Øint.: 17 PERKINS 26560919/26560143/26560142
 H.: 155 FILTRO FINAL
 Otros:



BR-1141P **1º**
 Øext.: 83 AGCO 3780931M1 / JCB 32/921001
 Øint.: 17 PERKINS 26560920 (PRE-FILTRO)
 H.: 135
 Otros:



BR-1154P **2º**
 Øext.: 83 CATERPILLAR 145-4501 / 223-0702
 Øint.: 17 FILTRO FINAL
 H.: 198
 Otros:



BR-1143P **1º**
 Øext.: 87 JOHN DEERE RE-529643 - JCB 32/925991
 Øint.: 17 (FLUJO INVERSO PRE-FILTRO GEN III)
 H.: 198
 Otros:



BR-1155H
 Øext.: 97 AGCO 4226295M1
 Øint.: M 22x1,5 CATERPILLAR 271-5076
 H.: 140
 Otros: M 10x1,5



BR-1144P **1º**
 Øext.: 87 AGCO 04805675 (PRIMARIO)
 Øint.: 17
 H.: 198
 Otros:



BR-1156P **2º**
 Øext.: 83 CAT 233-9856
 Øint.: 17 (FLUJO INVERSO FILTRO FINAL)
 H.: 155
 Otros:



BR-1145H
 Øext.: 110 RACOR R-4 2 / R-45 A
 Øint.: 1"x14 INT. NAVISTAR F-TT99N184A
 H.: 101
 Otros: M 95x2,5



BR-1157P **2º**
 Øext.: 83 JOHN DEERE RE-53727 / RE-62420
 Øint.: 17 RE-67901. FILTRO FINAL
 H.: 198
 Otros:



BR-1146H
 Øext.: 110 FORD F1H29365A
 Øint.: 1" X 14 N. HOLLAND 87840136 - 84446332
 H.: 132 (COSECH. TX65, TX62, TX66)
 Otros: M 95x2,5



BR-1158
 Øext.: 94 DEUTZ 01181245
 Øint.: M 16x1,50 (ALTA EFICIENCIA)
 H.: 140
 Otros:



BR-1147H
 Øext.: 110 HUYNDAI 11LB-20310
 Øint.: 1"x14 CASE 1685159C91
 H.: 160
 Otros: M 95x2,5



BR-1159P **2º**
 Øext.: 83 NEW HOLLAND 87802594
 Øint.: 17 PERKINS Mp10326
 H.: 155 (FLUJO INVERSO FILTRO FINAL)
 Otros:

BR

	BR-1160P Øext.: 85 Øint.: 10 - 13 H.: 184 Otros: M 8x1,5 FORD RANGER 3.0 TDI INTERNATIONAL 72136 MOTORCRAF R-FG-92 MB 710 9794770001
	BR-1170P 2º Øext.: 87 Øint.: 17 H.: 198 Otros: IVECO 504107584 (FILTRO FINAL GEN III)
	BR-1161P 2º Øext.: 83 Øint.: 17 H.: 198 Otros: CATERPILLAR 228-9130 (FLUJO INVERSO FILTRO FINAL)
	BR-1171H Øext.: 111 Øint.: 1"x14 UNF H.: 218 Otros: R. SENSOR 9/16x18 REEMP. CATERPILLAR 1R-0771 (USA RECIPIENTE COLECTOR)
	BR-1162P 2º Øext.: 87 Øint.: 17 H.: 155 Otros: JOHN DEERE RE-522868 (FILTRO FINAL GEN III.)
	BR-1172H Øext.: 111 Øint.: 1"x14 UNF H.: 180 Otros: R. SENSOR 9/16x18 CATERPILLAR 1R-0770 (USA RECIPIENTE COLECTOR)
	BR-1163P 2º Øext.: 83 Øint.: 17 H.: 198 Otros: JOHN DEERE RE-509032 LIEBHERR 7382111 (FILTRO FINAL)
	BR-1173P Øext.: 89 Øint.: 16 H.: 164 Otros: FORD TRANSIT 2.5 DIESEL RE/FG/25A
	BR-1164P 2º Øext.: 87 Øint.: 17 H.: 155 Otros: JOHN DEERE RE-520842 (FILTRO FINAL GEN III)
	BR-1174 Øext.: 76 Øint.: M 12x1,5 H.: 120 Otros: AGCO 4226296M1 PERKINS 2656F541 CATERPILLAR 1271-9385 F. ALTA EFICIENCIA
	BR-1165P 2º Øext.: 83 Øint.: 17 H.: 198 Otros: NEW HOLLAND 87801285 - 87802728 CASE 1931137-87802925 (FLUJO INVERSO FILTRO FINAL)
	BR-1175H Øext.: 97 Øint.: 1"x12 H.: 122 Otros: M 32x2,5 CNH 87610018 84465105 FLUJO INVERSO (USA CABEZAL CB-5036)
	BR-1166P 2º Øext.: 83 Øint.: 17 H.: 155 Otros: JOHN DEERE RE-509031 LIEBHERR 7090528 (FILTRO FINAL)
	BR-1176 Øext.: 96 Øint.: 1" X 14 UNF H.: 183 Otros: CATERPILLAR 1R-0750 ALTA EFICIENCIA
	BR-1167 Øext.: 97 Øint.: M 20x1,5 H.: 192 Otros: IVECO 2992241 KOMATSU 6754-71-6130 CARGO CUMMINS 4894548 4897833
	BR-1177P Øext.: 97 Øint.: 1"x12 H.: 165 Otros: CNH 87712547 (FLUJO INVERSO)
	BR-1168P 2º Øext.: 87 Øint.: 17 H.: 198 Otros: JOHN DEERE RE 521538/RE 522878 (FILTRO FINAL GEN III) AGCO 04805676
	BR-1178 Øext.: 96 Øint.: 3/4x16 H.: 140 Otros: SEP. DE AGUA PRIMARIO PARA REFORMA TOYOTA. USA SEC. RC 7113 (23390-0L010)
	BR-1169P Øext.: 90 Øint.: 10 - 10 12 H.: 120 - 101 Otros: M.BENZ SPRINTER ORIG. A611 092 1010.VITO
	BR-1179P Øext.: 77 Øint.: 3/4x16 H.: 143 Otros: MUSTANG 186933 CUMMINS C-6003117480



BR-1180P
 Øext.: 97
 Øint.: 9,5 - 8
 H.: 151
 Otros:

CHEV. S10 2,8 MWM TURBO
 (ELECTRONICO) GM 93380939
 MWM 905410500150



BR-1190H
 Øext.: 97
 Øint.: M20x1,50
 H.: 155
 Otros: M 32x2,5

DEUTZ - AGCO 04024879
 (BIODIESEL) FLUJO NORMAL
 (USA CABEZAL CB-5030)



BR-1181
 Øext.: 97
 Øint.: M 20x1,5
 H.: 192
 Otros:

CUMMINS 4897897
 FORD CARGO.



BR-1191H
 Øext.: 97
 Øint.: M 20x1,50
 H.: 155
 Otros: M 32x2,5

DEUTZ - AGCO 04020793
 (BIODIESEL) FLUJO INVERSO
 (USA CABEZAL CB-5020)



BR-1182
 Øext.: 97
 Øint.: 1x12 UNF
 H.: 215
 Otros:

VW 2R0127177E
 VOLVO 20841523
 MWM 9.0541.15.1.0027
 (ALTA EFICIENCIA)



BR-1192
 Øext.: 97
 Øint.: M 20x1,5
 H.: 183
 Otros:

CARGADORA MICHIGAN R95C
 C/MOTOR HANOMAG



BR-1183
 Øext.: 110
 Øint.: M 16x1,50
 H.: 170
 Otros:

IVECO 500315480 / 2994048
 NEW HOLLAND 1931108.



BR-1193
 Øext.: 78
 Øint.: M 16x1,50
 H.: 100
 Otros:

TRACTOR HANOMAG
 MOD. 350-354. H324001



BR-1184
 Øext.: 97
 Øint.: M 24x1,50
 H.: 142
 Otros:

SCANIA 1763776



BR-1194P
 Øext.: 94
 Øint.: M 16x1,50
 H.: 182
 Otros: M 14x2

TRACTOR AGRINAR T150-4
 MOTOR FPT.-FS 19908 YD



BR-1185
 Øext.: 97
 Øint.: M 18x1,50
 H.: 215
 Otros:

VOLVO 8193841/420799
 12.1L /20805349



BR-1195H
 Øext.: 110
 Øint.: 1"x14
 H.: 218
 Otros: M 95x2,5

AGCO 6265154M2
 FILTRACION PRIMARIA
 DE ALTA EFICIENCIA



BR-1186
 Øext.: 96
 Øint.: M 16x1,50
 H.: 215
 Otros:

EUROTECH 190 E31/180 E24
 IVECO STRALIS MOD.310
 ORIG. 2991585



BR-1196P
 Øext.: 97
 Øint.: M 16x1,50
 H.: 206
 Otros: M 10x1,50

IVECO 2992662
 DAILY 50C16 3.0 16VTB-IC
 ELECT.-STRALIS 310/380/420



BR-1187P
 Øext.: 83
 Øint.: M 16x1,5
 H.: 165
 Otros: M 8x1,25

NEW HOLLAND 87800220



BR-1197P
 Øext.: 88
 Øint.: M 16x1,50
 H.: 190
 Otros: M 12x1,50

IVECO 2992300
 DAILY 55C16 (3.0CRD I)



BR-1188
 Øext.: 97
 Øint.: 7/8x14 UNF
 H.: 176
 Otros:

CUMMINS 3959612
 CAMION VW 19-320
 (ALTA EFICIENCIA
 SISTEMA COMMON-RAIL)



BR-1198P
 Øext.: 97
 Øint.: 1"x14
 H.: 248
 Otros: 1/2x20 UNF

FORD HEAVY DUTY F100-150
 CUMMINS 4934158



BR-1189P
 Øext.: 97
 Øint.: 1"x14 UNF
 H.: 203
 Otros:

CUMMINS 3308638
 VOLVO 36849
 DOOSAN 65.12503-50168



BR-24H
 Øext.: 97
 Øint.: 1"x14
 H.: 92
 Otros: M 32x2,5

RACOR R-24 S
 HASTA 80HP.
 S/FLOW - DE ADENTRO
 HACIA FUERA.

BR



BR-26H

Øext.: 97 RACOR R-26 S; M.B. A3820927005
 Øint.: 1"x14 MAXION; CASE; N. HOLLAND R-468091
 H.: 122 AGCO/DEUTZ 04020385 - 036530 R1
 Otros: M 32x2,5 HASTA 120 HP S/FLOW DE ADENTRO HACIA FUERA



BR-28H

Øext.: 97 RACOR R-28 S; IVECO 7140553
 Øint.: 1"x14 HASTA 160HPS/FLOW -EUROTRAKRER
 H.: 155 EUROARGO DE ADENTRO
 Otros: M 32x2,5 HACIA FUERA.



BR-45H

Øext.: 110 RACOR R45A /FORD F-250
 Øint.: 1"x14 905411510019 - GM SILVERADO
 H.: 101 MOTOR MWM /VW MINIBUS
 Otros: M 95x2,5 914092/RD 127491. AGRALE 600700161905



BR-45P

Øext.: 110 (REEMP. BR-45H)
 Øint.: 1"x14 FORD E8TZ-9N 184A
 H.: 140
 Otros: C/PURGADOR



BR-45P/1

Øext.: 110 (REEMP. BR-45H)
 Øint.: 1"x14 FORD E8TZ-9N 184A
 H.: 140 MEDIDA JUNTA 90 - 76
 Otros: C/PURGADOR



BR-60H

Øext.: 110 RACOR R60A/M. BENZ A3760927001 K2
 Øint.: 1"x14 1214K -L-1218-1720-1723
 H.: 132 FORD BF-8X-9155-AA / MWM 9,0541,15,1,0020
 Otros: M 95x2,5 MWM 6,10 F1H2-9365A
 VW OMNIBUS 16210 CD. /2RP-127491



BR-60P

Øext.: 110 REEMPAL BR-60H
 Øint.: 1"x14 VOLKSWAGEN CAMION 7-100
 H.: 188 8-100 / 12-140
 Otros: C/PURGADOR



BR-60P/1

Øext.: 110 REEMPAL BR-60H
 Øint.: 1"x14 VOLKSWAGEN CAMION 7-100
 H.: 188 8-100 / 12-140
 Otros: C/PURGADOR MEDIDA JUNTA 90 - 76



BR-60PF

Øext.: 110 MERCEDES BENZ A-3760927301-L-LK1620
 Øint.: 1"x14 L1214C710 L0610/2002 -L1720A /
 H.: 188 1420/1421L K2 LINEA PRESION
 Otros: C/PURGADOR



BR-90H

Øext.: 110 RACOR R-90A /SCANIA 1393640
 Øint.: 1"x14 VOLVO 8159975-3989632
 H.: 160 VW 2TB 127491/OMNIBUS 17240 OT.
 Otros: M 95x2,5 VOLVO FH12-NH-12-360 NH-12-410/JOHN DEERE .



BR-90HM

Øext.: 110 IVECO 7147701 /EUROTECH
 Øint.: 1"x12 M. BENZ A 4570920001K2-1938
 H.: 160 ELECT.-L1935-L1938-LS1938
 Otros:



BR-90P

Øext.: 110 REEMP BR-90H
 Øint.: 1"x14 SCANIA 1681337 / 1393640
 H.: 223
 Otros: M 95x2,5)



BR-90P/1

Øext.: 110 REEMP BR-90H
 Øint.: 1"x14 SCANIA 1681337 / 1393640
 H.: 223 MEDIDA JUNTA 90 - 76
 Otros: M 95x2,5)



BR-90PF

Øext.: 110 M. BENZ A-4760927201
 Øint.: 1"x12 K2 OMNIBUS 0400 UPA
 H.: 218 PLE -0400RSD /LINEA PRESION
 Otros: M 95x2,5



BR-90PM

Øext.: 110 REEMP BR-90 HM
 Øint.: 1"x12 M. BENZ N° A457.092.001 KZ LS1632
 H.: 223
 Otros:



BR-120H

Øext.: 110 SCANIA 1518512 CAMIONES
 Øint.: 1"x14 OMNIBUS R124-T124LA
 H.: 180 P124CA-NZ360/420.-R164 GA-NZ480.
 Otros: M 95x2,5



BR-120HM

Øext.: 110 M. BENZ A3844777015KZ-1214C-1215
 Øint.: 1"x12 ELECTR.-1618 -712C-1914C
 H.: 218 ELECT.-L1623-L1723-LA1218
 Otros: M 95x2,5



BR-120PM

Øext.: 110 REEMP. BR-120HM
 Øint.: 1"x12 M.BENZ A-3844777015 K2
 H.: 252
 Otros: C/PURGADOR









BR-1200H

Øext.: 110 VW CAMION 17250
 Øint.: 1"x14 RACOR R-120VC/ R120L
 H.: 218 M. BENZ A000 4771302
 Otros: M 95x2,5



BR-1200H/4

Øext.: 110 CATERPILLAR 1335673
 Øint.: 1"x14 RACOR 120S./ MB 2R0127177C
 H.: 218 (ALTA EFICIENCIA) / VW 31-320
 Otros: M 95x2,5)

	<p>BR-1201HM</p> <p>Øext.: 110 M. BENZ ACTROS BRASIL Øint.: 1"x12 ORIG. A-9584770015KZ. H.: 218 Otros: M 95x2,5</p>
	<p>BR-1199P</p> <p>Øext.: 97 CUMMINS 3991498 Øint.: M 20x1,5 MOTOR B4,5 / B5,9 / QSB 4,5 H.: 195 QSB 5,9 TIER 2. Otros: M 14x2 ALTA EFICIENCIA (FINAL)</p>
	<p>BR-1203P</p> <p>Øext.: 97 CUMMINS 3800394 / 3406889 Øint.: 1"x14 CASE J800394 H.: 240 Otros: M 14x2</p>
	<p>BR-1205P</p> <p>Øext.: 97 CUMMINS 3973233 / 4931955 Øint.: 1"x14 MOTORES CUMMINS QSC, QSL TIER 3 H.: 240 CASE 87356193 Otros: M 14x2</p>
	<p>BR-1242H</p> <p>Øext.: 97 RACOR S-3201 Øint.: 1"x14 CUMMINS 3355903 / 3831871S H.: 172 MOTORCRAFT R/F6/77 Otros: M 32x2,5 S/F DE AFUERA HACIA ADENTRO</p>
	<p>BR-1316</p> <p>Øext.: 86 FORD MOTORCRAFT EFG 316 Øint.: 8 - 8 FIESTA / MONDEO 1.8 DIESEL H.: 173 Otros:</p>

EF

	<p>EF-0404</p> <p>Øext.: 264 RENUALT, CLIO 1,4 i RT, 1,6 RN, Øint.: 202 MEGANE 1.6i Honda Accord 1.6,1.8 H.: 62 Otros:</p>
	<p>EF-0405</p> <p>Øext.: 132 PEUGEOT 505 Øint.: 97 H.: 158 Otros:</p>
	<p>EF-0406</p> <p>Øext.: 123 FIAT DUNA S SC 1.4L / UNO SL Øint.: 64 FIORINO 1.1 / 1.3 / SPAZIO CL / TR H.: 207 Otros:</p>
	<p>EF-0407</p> <p>Øext.: 110 PEUGEOT 306 TURBO Øint.: 74 DIESEL XRD- XND 96 AL 99 H.: 242 Otros:</p>
	<p>EF-0408</p> <p>Øext.: 115 PEUGEOT 306 TURBO DIESEL Øint.: 74 XDR- XND 99 EN ADELANTE H.: 211 Otros:</p>
	<p>EF-0409</p> <p>Øext.: 166 PEUGEOT 306 DIESEL Øint.: 120 CITROEN ZX DIESEL H.: 123 Otros:</p>
	<p>EF-0410</p> <p>Øext.: 205 FIAT 147 - BRIO - DUNA S-SC 1.3 Øint.: 155 SPAZIO CL-TR 1.3- FIORINO - VIVACE H.: 45 Otros:</p>
	<p>EF-0411</p> <p>Øext.: 240 RENAULT 11 - RENAULT 9 Øint.: 185 RENAULT 19 RN H.: 62 Otros:</p>
	<p>EF-0412</p> <p>Øext.: 118 FIAT VIVACE 1.4 L 1995 Øint.: 77 N° 46593751 H.: 135 Otros:</p>
	<p>EF-0413</p> <p>Øext.: 178 RENUALT 19 GTX-RT-TXE Øint.: 88 DIESEL TT N° 7701034713 H.: 132 Otros:</p>
	<p>EF-0414</p> <p>Øext.: 284,5 VW GACEL NAFTERO - SENDA Øint.: 222 CARAT - GOL 1000 I - GOL 1.6 - 1.8 H.: 61,5 Otros:</p>
	<p>EF-0415</p> <p>Øext.: 276 RENAULT 12 TS-GTS- BREAK Øint.: 216 RENAULT 18 GTL H.: 55 Otros:</p>
	<p>EF-0416</p> <p>Øext.: 168 PEUGEOT 205 GLD/PARTNER DIESEL 1,8 Øint.: 119 306 DIESEL 1.9 N° 1444840 H.: 124 Otros:</p>
	<p>EF-0417</p> <p>Øext.: 154 RENAULT EXPRESS DIESEL 1.9 L Øint.: 94 CLIO NAFTERO / DIESEL H.: 179 Otros:</p>
	<p>EF-0418</p> <p>Øext.: 184 TOYOTA 17801 - 54030 Øint.: 78 ISUZU H.: 123 Otros:</p>
	<p>EF-0419</p> <p>Øext.: 146 ROVER MAESTRO ASU 1816 Øint.: 89 H.: 163 Otros:</p>
	<p>EF-0420</p> <p>Øext.: 314 F-100 C/MOTOR MAX ECONO Øint.: 258 FORD FTNL 129620 RA H.: 102 Otros:</p>
	<p>EF-0421</p> <p>Øext.: 162 DUCATTO DIESEL 1.9 - 2.5 Øint.: 100 H.: 178 Otros:</p>
	<p>EF-0422</p> <p>Øext.: 254 NISSAN 1600 - 1800 Øint.: 200 PATHFINDER - ISUZU LUV H.: 61 Otros:</p>
	<p>EF-0423</p> <p>Øext.: 238 - 232 SULLAIR 270006-322 Øint.: 172 ONAN Part. 140-1089 H.: 92 Otros:</p>

	<p>EF-0424</p> <p>Øext.: 127 Øint.: 86 H.: 311 Otros:</p> <p>CARCAZA CP-310 TRAFIC RODEO DIESEL TRAFIC 1.7</p>
---	---

	<p>EF-0434</p> <p>Øext.: 78 Øint.: 58 - 17 H.: 325 Otros:</p> <p>DEUTZ 3019767 PERKINS 004239 VALMET 800 62000 USA PRIM. EF-0440</p>
---	---

	<p>EF-0425</p> <p>Øext.: 314 Øint.: 257 H.: 59 Otros:</p> <p>FORD FALCON 82-89 PERKINS 4-203</p>
---	---

	<p>EF-0435</p> <p>Øext.: 91 Øint.: 70 - 17 H.: 344 Otros:</p> <p>DEUTZ 3019946 PERKINS 004240 VALMET 80062100 USA PRIM. EF-0441</p>
---	--

	<p>EF-0426</p> <p>Øext.: 156 Øint.: 112 H.: 56 Otros:</p> <p>ESPECIAL</p>
---	--

	<p>EF-0436</p> <p>Øext.: 109 Øint.: 91 - 17 H.: 374 Otros:</p> <p>DEUTZ 3019947 - PERKINS 004241 VALMET 802 70400 JOHN DEERE Dq04466 USA PRIM. EF-0443 y EF-0586</p>
---	---

	<p>EF-0427</p> <p>Øext.: 125 Øint.: 64 H.: 98 Otros:</p> <p>APLICACION CARCAZA CP-0027-0</p>
---	---

	<p>EF-0437</p> <p>Øext.: 121 Øint.: 100 - 17 H.: 380 Otros:</p> <p>DEUTZ 04002577 - AGCO 82649600 J. D. DQ-08522 - IVECO 7149135 N. HOLLAND 824846 - VALMET 80504300 USA PRIM. EF-0444 Y EF-0445</p>
---	---

	<p>EF-0428</p> <p>Øext.: 245 Øint.: 170 H.: 240 Otros:</p> <p>SULLAIR ORIGINAL N° 0098</p>
--	---

	<p>EF-0438</p> <p>Øext.: 138 Øint.: 120 - 17 H.: 480 Otros:</p> <p>AGCO 04802535 JOHN DEERE AZ-48196 SCANIA 110-111-116 VASSALLI - SEC. DEL EF-0447</p>
--	--

	<p>EF-0429</p> <p>Øext.: 245 Øint.: 170 H.: 140 Otros:</p> <p>FILTRO DE AIRE ESPECIAL</p>
---	--

	<p>EF-0439</p> <p>Øext.: 125 Øint.: 64 - 8,5 H.: 293 Otros:</p> <p>DEUTZ 3018713 - PERKINS 004226 M. FERG. 2710800AGCO M. BENZ 608 - ZANELLO</p>
---	---

	<p>EF-0430</p> <p>Øext.: 275 Øint.: 215 H.: 104 Otros:</p> <p>FILTRO DE AIRE COMPRESOR PERKINS 4-203, FORD F-100</p>
---	---

	<p>EF-0440</p> <p>Øext.: 149 Øint.: 71 - 8,5 H.: 335 Otros:</p> <p>DEUTZ 3018716 - PERKINS 004225 VALMET 80061900 ZANELLO - M. FERG.</p>
---	---

	<p>EF-0431</p> <p>Øext.: 127 Øint.: 65 H.: 219 Otros:</p> <p>CARCAZA CP-300 RENAULT 18 LX-X-GTX TRAFIC</p>
---	---

	<p>EF-0441</p> <p>Øext.: 165 Øint.: 86 - 8,5 H.: 352 Otros:</p> <p>DEUTZ 3018504 - VALMET 80061800 FORD 7000 - ZANELLO M. FERG - AGCO</p>
---	--

	<p>EF-0432</p> <p>Øext.: 244 Øint.: 170 H.: 95 Otros:</p> <p>CARCAZA CP-432 - CP-0030 PERKINS 4-203 FORD V8 ECONO 6 - PERKINS F-100</p>
---	--

	<p>EF-0442</p> <p>Øext.: 246 Øint.: 103 - 8,5 H.: 377 Otros:</p> <p>FIAT ALLIS 715105901 HUBER WARCO MOTONIVELADORA IND BRASILEIRA USA SEC. EF-0436</p>
---	--

	<p>EF-0433</p> <p>Øext.: 68 Øint.: 52 - 17 H.: 282 Otros:</p> <p>DEUTZ 3019768 - PERKINS 004238 MASSEY FERGUSON 2710801M1 USA PRIM. EF-0439</p>
---	--

	<p>EF-0443</p> <p>Øext.: 197 Øint.: 103 - 8,5 H.: 377 Otros:</p> <p>DEUTZ 3018372 - M. BENZ 0010945204 AGCO 03018372 - J. D. DQ04467 DODGE DD-900 DD-1000, ZANELLO - VALMET 80270500</p>
---	---

EF



EF-0444

Øext.: 276 - 227 ATLAS COPCO COMPRESORES
 Øint.: 115 - 11 JOHN DEERE AZ-23642
 H.: 383
 Otros:



EF-0454

Øext.: 292 CATERPILLAR N° 1P-7716 / 8N-5495
 Øint.: 205 USA SEC. EF-461
 H.: 342
 Otros:



EF-0445

Øext.: 227 DEUTZ 04002576 - IVECO 7140555
 Øint.: 117 - 11 KOMATSU 6003000121
 H.: 382 M. BENZ 1526 - J. D DQ-08521
 Otros: N. HOLLAND 824847 - VALTRA 82649500



EF-0455

Øext.: 160 - 231 CATERPILLAR N° 2S-1286
 Øint.: 118 4M 9335 / 4M-9339
 H.: 363 - 332 USA PRIM. EF-0452
 Otros:



EF-0446

Øext.: 305 - 242 SCANIA N 2118-11H.WARCO
 Øint.: 132 - 11 INDUSTRIA BRASILEIRA 69489
 H.: 496
 Otros:



EF-0456

Øext.: 234 CATERPILLAR N° 4M-8047
 Øint.: 123 USA SEC. EF-0458 / EF-0650
 H.: 317
 Otros:



EF-0447

Øext.: 242 SCANIA 219517/219517
 Øint.: 132 - 11 ATLAS COPCO 1619-2799-00
 H.: 496 J. D. AZ-48195 - M. BENZ 10945104
 Otros: AGCO 04802534 - CNH 84980416
 N. HOLLAND 80753486 - DEUTZ 04021006
 CUMMINS - ZANELLO - VASSALLI



EF-0457

Øext.: 448 KENWORT - WARCO VS - 2186
 Øint.: 280 - 23
 H.: 589
 Otros:



EF-0448

Øext.: 388 SCANIA T-112/R-112/H-112
 Øint.: 192 - 11 N° 370754 - 365729
 H.: 471
 Otros:



EF-0458

Øext.: 121 - 186 CATERPILLAR N° 2S-1285
 Øint.: 92
 H.: 337 - 306
 Otros:



EF-0449

Øext.: 125 PEUGEOT 504 DIESEL
 Øint.: 64 - 8,5 FALCON 2.4D RANCHERO
 H.: 216 MOTOR BORGWARD
 Otros:



EF-0459

Øext.: 353 SULLAIR ORIGINAL 250007 - 838
 Øint.: 255 - 14
 H.: 753
 Otros:



EF-0450

Øext.: 282 CATERPILLAR N° 7M-9045 / 7W-5316
 Øint.: 171 USA SEC. EF-0451
 H.: 420
 Otros:



EF-0460

Øext.: 250 SULLAIR ORIGINAL 250007 - 839
 Øint.: 205 - 14
 H.: 722
 Otros:



EF-0451

Øext.: 160 - 231 CATERPILLAR
 Øint.: 118 N° 2S-1287 / 7M-9046
 H.: 443 - 411 CUMMINS 253565
 Otros: GM-1528288



EF-0461

Øext.: 195 - 260 CATERPILLAR D8 N°
 Øint.: 154 1P-7360 / 4S-8340
 H.: 343 USA PRIM. EF-0893
 Otros:



EF-0452

Øext.: 282 CATERPILLAR N° 4M-9334 / 8N-5317
 Øint.: 171 USA SEC. EF-0453 ó EF-0455
 H.: 342
 Otros:



EF-0462

Øext.: 290 DEUTZ A 130
 Øint.: 200 - 14 N° 3009984
 H.: 318
 Otros:



EF-0453

Øext.: 160 - 231 CATERPILLAR N° 9S-9972
 Øint.: 118 USA PRIM. EF-0452
 H.: 332
 Otros:



EF-0463

Øext.: 199 DEUTZ A 130
 Øint.: 110 - 14 N° 3009982
 H.: 316
 Otros:

EF



EF-0484

Øext.: 109
Øint.: 91 - 17
H.: 454
Otros:

ZANELLO
USA PRIM. EF-0483



EF-0485

Øext.: 104 - 131
Øint.: 62 - 16
H.: 362
Otros:

NEW HOLLAND 221406
JOHN DEERE MG 221406
CASE R 39392
USA SEC. EF-0920



EF-0486

Øext.: 324
Øint.: 212
H.: 578
Otros:

MACK 57 MD 33



EF-0487

Øext.: 410 - 352
Øint.: 188 - 241
H.: 469
Otros:

GMC-IHC N 420051-CI
CUMMINS 3018042, 3630778
INTERNACIONAL
WHITE 220050001
SULLAIR N° 3018042



EF-0488

Øext.: 265
Øint.: 153
H.: 579
Otros:

SULLAIR N° 1401376
KENWORT-MACK 57 MD 26-67 MD27



EF-0489

Øext.: 199 - 155
Øint.: 89 - 16
H.: 390
Otros:

CASE D 56453
M. FERG. N° 1093682M91, 726199
KOMATSU - NEW HOLLAND
ALLIS CHALMERS 79011386
USA EF-0490 - EF-0491



EF-0490

Øext.: 85 - 105
Øint.: 74 - 16
H.: 359
Otros:

M. FERGUSON N° 1093683M92
ALLIS CHALMERS 79011387
AGCO 2424913070
CATERPILLAR 5W5890
USA PRIM. EF-0879



EF-0491

Øext.: 85 - 95
Øint.: 76 - 16
H.: 359
Otros:

M. FERGUSON N° 1037735M91
IHC 529852 R1
INTERNACIONAL 406130 R91
CASE 250566 - NEW HOLLAND 377059



EF-0493

Øext.: 224
Øint.: 140
H.: 190
Otros:

MACK 57 MD 32



EF-0495

Øext.: 222 - 173
Øint.: 107 - 16
H.: 385
Otros:

J.DEERE AJ55130-3530-4530
PRIMARIO



EF-0496

Øext.: 104
Øint.: 75 - 16
H.: 358
Otros:

J.DEERE AJ 55131 - 3530 - 4530
SEC. ZETOR 12045



EF-0497

Øext.: 222 - 173
Øint.: 107 - 16
H.: 268
Otros:

J.DEERE AL 27158
450-544-544A-570-570A
2420-2840-3420-4420



EF-0498

Øext.: 104
Øint.: 63 - 17
H.: 186
Otros:

J.DEERE AT 25219
450-544-544A-570-570A
2420-3420-4420

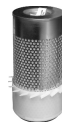

EF-0499

Øext.: 162 - 133
Øint.: 66 - 17
H.: 290
Otros:

A. CHALMERS - CASE - MICHIGAN
CLARK - JOHN DEERE AL 17255-310
350-350D-380-400-401A-401B-401C
410-440-440A-440B-1120
2120-2020-1250-1530-2010
2010C-2010D.MIT-L300



EF-0500

Øext.: 131 - 104
Øint.: 62 - 17
H.: 264
Otros:

A. CHALMERS - CLARCK
MICHIGAN - J. DEERE
FIAT 1540111060
USA SEC. EF-0525

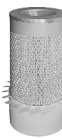

EF-0501

Øext.: 198 - 155
Øint.: 88 - 17
H.: 340
Otros:

AGRITEC FIAT N° 1909116
680-780-880-IMP. 980
J. DEERE 5400 RE 45827
USA SEC. EF-0502



EF-0502

Øext.: 95
Øint.: 76 - 16
H.: 307
Otros:

AGRITEC FIAT N° 1909117
680-780-880-IMP. 980
J. DEERE 5400 RE 45828
USA PRIM. EF-0501



EF-0503

Øext.: 264
Øint.: 153
H.: 211
Otros:

CATERPILLAR N° 4L-9851, 4L-9892



EF-0504

Øext.: 324
Øint.: 213 - 213
H.: 229
Otros:

MACK 57 MD 21 - 57 MD 21A





EF-0505

Øext.: 162 - 133
Øint.: 82 - 17
H.: 312
Otros:

JOHN DEERE AE 31723
940-1030-1040-1250
2630-2640-2130-2140

	<p>EF-0506</p> <p>Øext.: 92 Øint.: 61 - 17 H.: 283 Otros:</p> <p>J. DEERE AL 27159 1450-2140-2130-2630-2640</p>
---	--

	<p>EF-0516</p> <p>Øext.: 213 - 255 Øint.: 89 - 13 H.: 373 Otros:</p> <p>JOHN DEERE ORIG. AL 30394 3140, 2850, 3350, 3550</p>
---	---

	<p>EF-0507</p> <p>Øext.: 307 Øint.: 196 - 23 H.: 521 Otros:</p> <p>SULLAIR N° 46968 TEREX PALA CARGADORA 72-31-9052907-DQ-43482</p>
---	--

	<p>EF-0517</p> <p>Øext.: 95 Øint.: 76 - 16 H.: 331 Otros:</p> <p>JOHN DEERE ORIG. AL 30395 3140, 2850, 3350, 3550</p>
---	--

	<p>EF-0508</p> <p>Øext.: 195 Øint.: 153 - 23 H.: 470 Otros:</p> <p>SULLAIR N° 46981 TEREX PALA CARGADORA 72-31-9031711</p>
---	---

	<p>EF-0518</p> <p>Øext.: 324 Øint.: 213 - 22 H.: 622 Otros:</p> <p>INGERSOLL RAND COMPRESORES N° 35123512 PRIMARIO FHG 16</p>
---	--

	<p>EF-0509</p> <p>Øext.: 173 Øint.: 88 - 22 H.: 315 Otros:</p> <p>CAT. 4N-326X, 4N-0326 J. DEERE AR 43605, AR 43491 AIR MAZE 202633-826</p>
---	--

	<p>EF-0519</p> <p>Øext.: 209 Øint.: 180 - 22 H.: 569 Otros:</p> <p>INGERSOLL RAND COMPRESORES N° 35123520 CLARK N° 691 417 SECUNDARIO FHG 16</p>
---	---

	<p>EF-0510</p> <p>Øext.: 86 Øint.: 56 - 17 H.: 262 Otros:</p> <p>CATERPILLAR N° 4N-0313</p>
---	--

	<p>EF-0520</p> <p>Øext.: 234 Øint.: 123 - 17 H.: 340 Otros:</p> <p>AGRITEC N° 1909136 FIAT N° 70684733 1100E, 1180, 115, 80, 1380, 1380T, 1580, 1880, 160, 90, 180, 90 FIAT ALLIS N° 73050258, 70660360 J. DEERE 644 B - USA SEC. EF-0521</p>
--	--

	<p>EF-0511</p> <p>Øext.: 155 Øint.: 107 - 16 H.: 338 Otros:</p> <p>J. DEERE AJ 55127 308-309-2330-2530 2730-3330</p>
---	---

	<p>EF-0521</p> <p>Øext.: 116 Øint.: 88 - 17 H.: 311 Otros:</p> <p>AGRITEC N° 1909135 FIAT N° 706626 USA PRIM. EF-0520 ó EF-0524</p>
---	--

	<p>EF-0512</p> <p>Øext.: 104 Øint.: 75 - 16 H.: 308 Otros:</p> <p>J. DEERE ORIG. N° AJ 55128 308-309-2330-2530 2730-3330</p>
---	---

	<p>EF-0522</p> <p>Øext.: 162 - 133 Øint.: 66 - 17 H.: 290 Otros:</p> <p>AGRITEC N° 1909139 M. FERGUSON N° 1043326M91 FIAT 446, 55, 46, 666, 80, 66, 70, 66 MIT-L-300 - USA EF-0523</p>
---	---

	<p>EF-0513</p> <p>Øext.: 356 Øint.: 241 - 13 H.: 356 Otros:</p> <p>FIAT ALLIS CUMMINS 151688-299362 MACK MICHIGAN CAT 9L3420 (FILT. DENTRO HACIA FUERA)</p>
---	--

	<p>EF-0523</p> <p>Øext.: 80 - 65 Øint.: 55 - 17 H.: 255 Otros:</p> <p>AGRITEC N° 1909138 M. FERGUSON N° 104337 M91 FIAT 446, 55, 46, 666, 80, 66, 70, 66 KOMATSU 3EB0225550</p>
---	--

	<p>EF-0514</p> <p>Øext.: 333 Øint.: 244 H.: 151 Otros:</p> <p>ELEM. PRIMARIO CP-514 M. BENZ 1112-1114 PERKINS 6-354</p>
---	--

	<p>EF-0524</p> <p>Øext.: 278 - 235 Øint.: 123 - 15 H.: 340 Otros:</p> <p>AGRITEC N° 1930174, 1930349 USA SEC. EF-0521</p>
---	--

	<p>EF-0515</p> <p>Øext.: 225 Øint.: 212 - 17 H.: 120 Otros:</p> <p>ELEM. DE SEG. CP-514 M. BENZ 1112-1114 PERKINS 6-354</p>
---	--

	<p>EF-0525</p> <p>Øext.: 60 Øint.: 50 - 17 H.: 232 Otros:</p> <p>AGRITEC N° 1528711490 KOMATSU 3EB 0219840</p>
---	---

EF



EF-0526

Øext.: 351
Øint.: 254 - 254
H.: 517
Otros: SULLAIR N° 27003-139

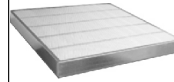

EF-0536

Largo: 610
Ancho: 610
Alto: 65
Otros: CATERPILLAR 6L-4714



EF-0527

Øext.: 225
Øint.: 147
H.: 732
Otros: GMC CAMION GM 2017021



EF-0537

Øext.: 490
Øint.: 328
H.: 260
Otros: CATERPILLAR 8N-6309



EF-0528

Øext.: 225
Øint.: 147
H.: 584
Otros: MACK 57 MD 24



EF-0538

Øext.: 185
Øint.: 102 - 10
H.: 390
Otros: J. DEERE AR-54336 AIR MAZE CD 0916514-826



EF-0529

Øext.: 351
Øint.: 241 - 22
H.: 520
Otros: SULLAIR N° 46299



EF-0539

Øext.: 100
Øint.: 80 - 16,3
H.: 336,5
Otros: J. DEERE AR-54337



EF-0530

Øext.: 219
Øint.: 178 - 22
H.: 470
Otros: SULLAIR N° 47523



EF-0540

Øext.: 206
Øint.: 146 - 8
H.: 112
Otros: SULLAIR N° 42445



EF-0531

Øext.: 199 - 155
Øint.: 88 - 17
H.: 311
Otros: J. DEERE N° AQX 113760, 94573, 21X11984A, 440C, 540B BOBCAT 6681474



EF-0541

Øext.: 202
Øint.: 135 - 17
H.: 416
Otros: F. CARGO 1416 TEG129620-A, CHALMERS 335203 CAMION VW 15-160 C/M CUMMINS 180HP



EF-0532

Øext.: 85
Øint.: 72 - 17
H.: 282
Otros: J. DEERE N° AT 443378 440C, 540B BOBCAT 6681475



EF-0542

Øext.: 343
Øint.: 178
H.: 610
Otros: FARR N° 71338-003 CAUDAL 2720 m3/h



EF-0533

Øext.: 373
Øint.: 262 - 22
H.: 623
Otros: M. FERGUSON N° 1037735M91 IHC 529852 R1 INTERNACIONAL 406130 R91 CASE 250566 - NEW HOLLAND 377059



EF-0543

Øext.: 343
Øint.: 178
H.: 457
Otros: FARR N° 71338-004 CAUDAL 2380 m3/h



EF-0534

Øext.: 260
Øint.: 232 - 22
H.: 597
Otros: CUMMINS 3013213 ZANELLO 700 C



EF-0544

Øext.: 248
Øint.: 152
H.: 610
Otros: FARR N° 71338-001 CAUDAL 1700 m3/h



EF-0535

Øext.: 213
Øint.: 147 - 13
H.: 241
Otros: CUMMINS 133739, 2992285 GM





EF-0545

Øext.: 279
Øint.: 178
H.: 610
Otros: FARR N° 71338-002 CAUDAL 2380 m3/h

	<p>EF-0546</p> <p>Øext.: 230 ONAN 140-2241 Øint.: 122 - 10 J. DEERE AR-61967 H.: 432 AIR MAZE CD 1117-505-826 Otros:</p>
---	---

	<p>EF-0556</p> <p>Øext.: 351 ALLIS CHALMERS 690305 Øint.: 240 - 23 TEREX 9036292, 9038907 H.: 568 Otros:</p>
---	--

	<p>EF-0547</p> <p>Øext.: 119 J. DEERE AR 61968, Øint.: 100 - 17 AR 79680 H.: 631 Otros:</p>
---	---

	<p>EF-0557</p> <p>Øext.: 219 ALLIS CHALMERS 690304 Øint.: 178 - 23 TEREX 9036293 H.: 533 Otros:</p>
---	---

	<p>EF-0548</p> <p>Øext.: 351 EUCLID - TEREX 9035992 Øint.: 241 - 23 AGCO 71409552 H.: 470 Otros:</p>
---	--

	<p>EF-0558</p> <p>Øext.: 458 ING. RAND 300 AIR COMPRESOR Øint.: 328 SULLAIR N° 40402 W-103031 A H.: 698 Otros:</p>
---	--

	<p>EF-0549</p> <p>Øext.: 219 EUCLID - TEREX 9035993 Øint.: 178 - 23 AGCO 71409553 H.: 433 Otros:</p>
---	--

	<p>EF-0559</p> <p>Øext.: 264 J. DEERE AE-30508 Øint.: 154 - 23 IHC - 627127 - C1 H.: 417 Otros:</p>
---	---

	<p>EF-0550</p> <p>Øext.: 264 CUMMINS - ALLIS CHALMERS Øint.: 198 - 12 MACK GM H.: 316 Otros:</p>
--	--

	<p>EF-0560</p> <p>Øext.: 151 J. DEERE AE 30507 Øint.: 123 - 23 IHC 627128-C1 H.: 364 Otros:</p>
--	---

	<p>EF-0551</p> <p>Øext.: 264 VOLVO 347437 Øint.: 198 - 198 H.: 271 Otros:</p>
---	--

	<p>EF-0561</p> <p>Largo: 381 CATERPILLAR 4N-0015 Ancho: 381 Alto: 141 Otros:</p>
---	---

	<p>EF-0552</p> <p>Øext.: 308 ALLIS CHALMERS - AC 671838-1 Øint.: 195 - 23 H.: 597 Otros:</p>
---	---

	<p>EF-0562</p> <p>Øext.: 162 - 133 MASSEY FERGUSON MF-22C Øint.: 92 - 17 CARGADORA N° 142-8739-M91 H.: 392 USA SEC. EF-0491 Otros:</p>
---	---

	<p>EF-0553</p> <p>Øext.: 194 ALLIS CHALMERS AC 671839-4 Øint.: 153 - 23 H.: 546 Otros:</p>
---	---

	<p>EF-0563</p> <p>Øext.: 264 ALLIS CHALMERS - CUMMINS Øint.: 154 - 14 EUCLID - GALION GMC H.: 230 HOUGH - HYSTER- IH Otros: MACK - WHITE.</p>
---	---

	<p>EF-0554</p> <p>Øext.: 264 ALLIS CHALMERS CASE A-43656 Øint.: 154 - 23 H.: 368 Otros:</p>
---	--

	<p>EF-0564</p> <p>Øext.: 214 KOMATSU 600-300-0110 Øint.: 108 H.: 427 Otros:</p>
---	--

	<p>EF-0555</p> <p>Øext.: 151 ALLIS CHALMERS CASE A-43657 Øint.: 123 - 23 H.: 314 Otros:</p>
---	--

	<p>EF-0565</p> <p>Øext.: 105 - 171 KOMATSU 600-300-0121 Øint.: 73 H.: 449 Otros:</p>
---	---

EF



EF-0566

Øext.: 448
Øint.: 311 - 23
H.: 597
Otros: WABCO VJ-0075 VJ-5175



EF-0576

Øext.: 365
Øint.: 210 - 17
H.: 416
Otros: VOLVO N° 6888848



EF-0567

Øext.: 302
Øint.: 257 - 23
H.: 571
Otros: WABCO VJ-5176



EF-0577

Øext.: 197
Øint.: 165 - 17
H.: 367
Otros: VOLVO N° 6888857



EF-0568

Øext.: 281
Øint.: 171 - 17
H.: 342
Otros: WHITE 3107361



EF-0578

Øext.: 85
Øint.: 25
H.: 92
Otros: VOLVO N° 6888780
RESPIRADERO N° 1586882-1



EF-0569

Øext.: 256 - 201
Øint.: 91 - 14
H.: 270
Otros: GM- JOHN DEERE



EF-0579

Øext.: 300
Øint.: 198 - 198
H.: 112
Otros: ATLAS COPCO
1030 1070, 1030-0832



EF-0570

Øext.: 201 - 256
Øint.: 135 - 17
H.: 419
Otros: ALLIS CHALM. 654409,
CUMMINS 196677,
M. FERGUSON1428745-M91,
JOHN DEERE 750-755
USA SEC. EF-0571/0622/0799



EF-0580

Øext.: 170
Øint.: 95 - 12
H.: 287
Otros: SULLAIR
N° 250022-888



EF-0571

Øext.: 116 - 142
Øint.: 88 - 17
H.: 398
Otros: FIAT ALLIS 7662608,
M. FERGUSON 14 28747 M 91,
J. DEERE 750-755



EF-0581

Øext.: 343
Øint.: 178
H.: 381
Otros: FARR N° 71338 - 005



EF-0572

Øext.: 217
Øint.: 110 - 110
H.: 85
Otros: GM 914215 911919
NORTORF, ISIZU 9-14215-1010



EF-0582

Øext.: 302
Øint.: 192 - 11
H.: 472
Otros: M. BENZ 1938 N° 38809747004
SCANIA 531050
AGCO 09008546M1
FIAT IVECO 190 TURBO N° 1904550



EF-0573

Øext.: 116 - 142
Øint.: 88 - 17
H.: 330
Otros: FIAT ALLIS 7662607,
J. DEERE AR 46004,
J. DEERE 644 B
USA PRIM. EF-520

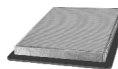

EF-0583

Largo: 205
Ancho: 205
Alto: 20
Otros: VOLVO N° 6884234
81280045



EF-0574

Øext.: 282 - 351
Øint.: 171 - 14
H.: 318
Otros: CUMMINS 158878, 299351
ALLIS CHALMERS - EUCLID - GM



EF-0584

Øext.: 110 - 84
Øint.: 42 - 11
H.: 184
Otros: ALLIS CHALMERS 70247060



EF-0575

Largo: 495
Ancho: 495
Alto: 144
Otros: SATURN & SOLAR
IND.TURBINE ENGINES





EF-0585

Øext.: 324
Øint.: 212 - 212
H.: 378
Otros: MACK 57 MD 29301

	<p>EF-0586</p> <p>Øext.: 167 Øint.: 106 - 17 H.: 391 Otros:</p> <p>FORD 14000 MOTOR MWM 6-4 FORD 100 MOD. 94</p>
---	---

	<p>EF-0596</p> <p>Øext.: 106 - 83 Øint.: 42 - 11 H.: 184 Otros:</p> <p>ONAN 140 P842 ALLIS CHALMERS 247060</p>
---	---

	<p>EF-0587</p> <p>Øext.: 323 Øint.: 213 H.: 378 Otros:</p> <p>MACK 57 MD 31 A</p>
---	--

	<p>EF-0597</p> <p>Øext.: 324 Øint.: 212 H.: 686 Otros:</p> <p>KENWORTH WHITE</p>
---	---

	<p>EF-0588</p> <p>Øext.: 160 - 151 Øint.: 140 - 17 H.: 472 Otros:</p> <p>SCANIA 534157 MERCEDES BENZ USA PRIM. EF-0448 / EF-0582</p>
---	---

	<p>EF-0598</p> <p>Øext.: 197 Øint.: 135 - 17 H.: 378 Otros:</p> <p>M. FERGUSON COSECHADORA 3468368 M91 USA SEC. EF-0599</p>
---	--

	<p>EF-0589</p> <p>Øext.: 353 Øint.: 189 - 17 H.: 469 Otros:</p> <p>GM 12 V 149</p>
---	---

	<p>EF-0599</p> <p>Øext.: 116 - 142 Øint.: 88 - 17 H.: 353 Otros:</p> <p>M. FERGUSON USA PRIM. EF-0598</p>
---	--

	<p>EF-0590</p> <p>Largo: 640 Ancho: 200 Alto: 25 Otros:</p> <p>ARAUS Nº 31516510</p>
---	---

	<p>EF-0600</p> <p>Øext.: 264 Øint.: 154 - 23 H.: 470 Otros:</p> <p>ALLIS CHALMERS 269244 STEIGER</p>
--	---

	<p>EF-0591</p> <p>Øext.: 165 Øint.: 86 H.: 212 Otros:</p> <p>DEUTZ Nº 2339813 K2 FENOT</p>
---	---

	<p>EF-0601</p> <p>Øext.: 150 Øint.: 123 - 17 H.: 416 Otros:</p> <p>ALLIS CHALMERS 269245 STEIGER</p>
---	---

	<p>EF-0592</p> <p>Øext.: 165 Øint.: 86 H.: 331 Otros:</p> <p>DEUTZ Nº 2339823 K21008-43</p>
---	--

	<p>EF-0602</p> <p>Øext.: 375 - 307 Øint.: 196 - 23 H.: 472 Otros:</p> <p>KOMATSU 6128-81-7320, 600-181-4400 USA SEC. EF-0707</p>
---	---

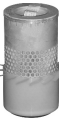
	<p>EF-0593</p> <p>Øext.: 131 - 104 Øint.: 62 - 17 H.: 200 Otros:</p> <p>NISSAN 165405H10</p>
---	---

	<p>EF-0603</p> <p>Øext.: 353 Øint.: 190 H.: 660 Otros:</p> <p>GMC 717714</p>
---	---

	<p>EF-0594</p> <p>Øext.: 242 Øint.: 165 - 10 H.: 723 Otros:</p> <p>GMC 2067009 ASTRO-WHITE</p>
---	---

	<p>EF-0604</p> <p>Øext.: 352 Øint.: 241 H.: 596 Otros:</p> <p>CATERPILLAR 3406 CUMMINS 400</p>
---	---

	<p>EF-0595</p> <p>Øext.: 243 Øint.: 171 - 8 H.: 93 Otros:</p> <p>PERKINS 4203</p>
---	--

	<p>EF-0605</p> <p>Øext.: 213 - 177 Øint.: 88 - 15 H.: 342 Otros:</p> <p>FIAT AGRI 1930138 USA SEC. EF-0532</p>
---	---

EF



EF-0606

Øext.: 154
Øint.: 89 - 17
H.: 313
Otros:

J. DEERE AR-46481
ISUZU, USA SEC. EF-0532



EF-0607

Øext.: 174 - 222
Øint.: 108 - 17
H.: 383
Otros:

FIAT ALLIS 70266787
USA SEC. EF-0608



EF-0608

Øext.: 104 - 222
Øint.: 90 - 17
H.: 383
Otros:

FIAT ALLIS 70267953
USA PRIM. EF-0607



EF-0609

Øext.: 232
Øint.: 147 - 23
H.: 469
Otros:

CA.S-238646 / J. DEERE AT-81018
CHAMPION 720-730 - 28120
USA SEC. EF-0610



EF-0610

Øext.: 145
Øint.: 117 - 17
H.: 444
Otros:

CASE - J. DEERE
CHAMPION 720 - 730 - 28120
USA PRIM. EF-0609



EF-0611

Øext.: 234 - 295
Øint.: 123 - 14
H.: 266
Otros:

CUMMINS 157877
FIAT ALLIS AD 18 (4971958)



EF-0612

Øext.: 307
Øint.: 196 - 14
H.: 254
Otros:

CUMMINS - MACK
MICHIGAN



EF-0613

Øext.: 133 - 162
Øint.: 72 - 17
H.: 240
Otros:

NISSAN 16546-40 K00
1654651760



EF-0614

Øext.: 299
Øint.: 170
H.: 401
Otros:

BELOTOMAK AA3 238H 1109080



EF-0615

Øext.: 256
Øint.: 127 - 11
H.: 390
Otros:

KAMAZ DC 740 1109560-01



EF-0616

Øext.: 214 - 155
Øint.: 88 - 13
H.: 393
Otros:

LANDINI POCLAIN T1950555
GRUA P Y H N° 906041023
USA SEC. EF-0490



EF-0617

Øext.: 213 - 177
Øint.: 88 - 15
H.: 280
Otros:

M. FERGUSON 3595500-M1



EF-0618

Øext.: 85
Øint.: 74 - 16
H.: 229
Otros:

M. FERGUSON 3595501-M1
3515587 M1
J. DEERE AT-68184



EF-0619

Øext.: 307
Øint.: 196 - 23
H.: 470
Otros:

AGCO 71368961
CASE 680587C2
IH680587-C1
MF 9790 / USA SEC. EF-0620/



EF-0620

Øext.: 194
Øint.: 153 - 23
H.: 441
Otros:

AGCO 71368962
CASE 672020C1
IH680588-C1
MF 9790 / USA PRIM. EF-0619



EF-0621

Øext.: 280 - 201
Øint.: 135 - 16
H.: 418
Otros:

FIAT ALLIS 71415282
USA SEC. EF-0622



EF-0622

Øext.: 116
Øint.: 88 - 17
H.: 386
Otros:

M. FERG 1426450 M-91
USA PRIM. EF-0621 / EF-0678



EF-0623

Øext.: 275
Øint.: 171 - 17
H.: 445
Otros:

DAEWOO CAMION 96085527
USA SEC. EF-0624



EF-0624

Øext.: 163
Øint.: 134 - 17
H.: 419
Otros:

DAEWOO CAMION
USA PRIM. EF-0623





EF-0625

Øext.: 257
Øint.: 201
H.: 61
Otros:

NISSAN PATHFINDER 16546-67300
ISUZU LUV 8-942060070

	<p>EF-0626</p> <p>Øext.: 275 DRESSER 1249055 H1; KU Øint.: 171 - 23 J. DEERE AR 85242 H.: 470 Otros:</p>
---	---

	<p>EF-0636</p> <p>Øext.: 92 FORD E4NN-9R500 BA Øint.: 76 - 14 USA PRIM. EF-0635 H.: 355 Otros:</p>
---	---

	<p>EF-0627</p> <p>Øext.: 163 DRESSER 1249056 H1; KU Øint.: 133 - 17 J. DEERE AR 85241 H.: 445 Otros:</p>
---	---

	<p>EF-0637</p> <p>Øext.: 275 CHAMPION 740 Øint.: 171 - 22 HYUNDAI 11L12003 H.: 520 CASE 150783A1 Otros: USA SEC. EF-0638</p>
---	---

	<p>EF-0628</p> <p>Øext.: 154 CHEVROLET C/MOTOR ISUZU 2.8 DIESEL Øint.: 80 NISSAN / LUV.DIESEL 8-94334906-N H.: 163 Otros:</p>
---	--

	<p>EF-0638</p> <p>Øext.: 163 CHAMPION 740 Øint.: 133 - 16 HYUNDAI 11L12004 H.: 495 CASE 151397A1 Otros: USA PRIM. EF-0637</p>
---	--

	<p>EF-0629</p> <p>Øext.: 155 TOYOTA 2000 NAF. 17801-3150 Øint.: 88 - 12 DIESEL 2.4/17801-54080 H.: 198 Otros:</p>
---	--

	<p>EF-0639</p> <p>Øext.: 264 FORD D 5 HZ 9601 D Øint.: 153 H.: 405 Otros:</p>
---	---

	<p>EF-0630</p> <p>Largo: 158 - 133 A-173290 / CASE 580SUPER K Ancho: 82 - 17 M. FERG. 1040764 Alto: 387 USA SEC. EF-0631 Otros:</p>
--	---

	<p>EF-0640</p> <p>Øext.: 302 SCANIA 395773 Øint.: 197 - 11 CAMION P-93 M93-210 H.: 377 USA SEC. EF-0641 Otros:</p>
--	--

	<p>EF-0631</p> <p>Øext.: 93 - 75 A 173291 / CASE 580 SUPER K Øint.: 61 - 17 USA PRIM. EF-0630 H.: 357 Otros:</p>
---	---

	<p>EF-0641</p> <p>Øext.: 150 - 145 SCANIA 3760948004 Øint.: 135 USA PRIM. EF-0640 H.: 420 Otros:</p>
---	---

	<p>EF-0632</p> <p>Øext.: 233 ALLIS CH. 264744 Øint.: 149 - 17 CASE - ZANELLO 250 MOD.97 H.: 445 USA SEC. EF-0633 Otros:</p>
---	---

	<p>EF-0642</p> <p>Øext.: 233 CAMION NISSAN - CAT. 7Y-0404 Øint.: 147 - 22 USA SEC. EF-0643 H.: 343 Otros:</p>
---	--

	<p>EF-0633</p> <p>Øext.: 141 ALLIS CH. 264745 Øint.: 112 - 17 CASE ZANELLO 250 MOD. 97 H.: 396 USA PRIM. EF-0632 Otros:</p>
---	---

	<p>EF-0643</p> <p>Øext.: 145 CAMION NISSAN - CAT. 5I-5208 Øint.: 115 - 16 USA PRIM. EF-0642 H.: 317 Otros:</p>
---	---

	<p>EF-0634</p> <p>Øext.: 149 MERCEDES BENZ 180D Øint.: 71 OM-616 H.: 214 Otros:</p>
---	--

	<p>EF-0644</p> <p>Øext.: 202 CAMION ISUZU 3Y25 - 894156052 Øint.: 134 - 22 NPR-4.3 CHEVROLET H.: 266 Otros:</p>
---	--

	<p>EF-0635</p> <p>Øext.: 187 - 169 FORD E4NN-9601 BA Øint.: 96 - 11 USA SEC. EF-0636 H.: 383 Otros:</p>
---	--

	<p>EF-0645</p> <p>Øext.: 198 - 155 MITSUBISHI L-200 / MD 620109 Øint.: 89 - 12 (L-200 2,5 CC DIESEL) H.: 157 Otros:</p>
---	--

EF



EF-0646

Øext.: 155
Øint.: 80
H.: 198
Otros:

ISUZU TROOPER 4 X 4
(8-97044226) 2.8



EF-0647

Øext.: 234
Øint.: 123 - 12,5
H.: 424
Otros:

FIAT ALLIS Ad20
USA SEC. EF-0648



EF-0648

Øext.: 122
Øint.: 94 - 12
H.: 405
Otros:

FIAT ALLIS Ad20
USA PRIM. EF-0647



EF-0649

Øext.: 264
Øint.: 198 - 133
H.: 266
Otros:

CAT. 2M-2626, 2S-555,
3S-9606



EF-0650

Øext.: 120 - 186
Øint.: 92
H.: 307
Otros:

CATERPILLAR 8N-4901
USA PRIM. EF-0456



EF-0651

Øext.: 155 - 198
Øint.: 89 - 12
H.: 200
Otros:

MONTERO TROOPER 4 X 4
MITSUBISHI L200
2.5 DTD, 2.5 TDI



EF-0652

Øext.: 133
Øint.: 72 - 17
H.: 290
Otros:

LAND ROVER (ESR 2623)



EF-0653

Øext.: 190
Øint.: 83
H.: 150
Otros:

TOYOTA AUTOELEVADORES
17801-48010, 17801-48011,
23303-30205-71, 17801-58010



EF-0654

Øext.: 133
Øint.: 66 - 12
H.: 290
Otros:

HYUNDAI 28130-44000
CAMION



EF-0655

Øext.: 222 - 174
Øint.: 106 - 16
H.: 368
Otros:

CASE A47032
CARGADORA 621 B
USA SEC. EF-0656



EF-0656

Øext.: 122 - 104
Øint.: 92 - 16
H.: 332
Otros:

CASE A47033
CARGADORA 621 B
USA PRIM. EF-0655



EF-0657

Øext.: 264
Øint.: 153 - 17
H.: 419
Otros:

FORD CARGO 1722- 1730- 2422- 2425
TJG 129620 / MOTORCRAFT R-FA-25
USA SEC. EF-0658



EF-0658

Øext.: 151 - 141
Øint.: 126 - 17
H.: 378
Otros:

FORD CARGO 1722-1730
TJG 129620 A
USA PRIM. EF-0657



EF-0659

Øext.: 222
Øint.: 154 - 154
H.: 206
Otros:

FIAT ALLIS Ad10,
AD10B, AD12, Ad14
USA SEC. EF-0660



EF-0660

Øext.: 138
Øint.: 100 - 100
H.: 176
Otros:

FIAT ALLIS Ad10,
AD10B, AD12, Ad14
USA PRIM. EF-0659



EF-0661

Øext.: 139 - 128
Øint.: 115 - 17
H.: 392
Otros:

F. CARGO 1416 TEG 129620A
CAMION VW 15-160
C/M CUMMINS 180HP
USA PRIM. EF-0541



EF-0662

Øext.: 264
Øint.: 153 - 23
H.: 305
Otros:

DODGE RAM - FORD
CUMMINS
USA SEC. EF-0663



EF-0663

Øext.: 151
Øint.: 123 - 17
H.: 280
Otros:

DODGE RAM - FORD
CUMMINS
USA PRIM. EF-0662



EF-0664

Øext.: 155
Øint.: 75 - 12
H.: 162
Otros:

MAZDA 2.2 DIESEL





EF-0665

Øext.: 217
Øint.: 110
H.: 144
Otros:

TOYOTA HILUX 3000 TURBO
4 X4 Nº 17801-67060

	<p>EF-0666</p> <p>Øext.: 155 Øint.: 87 H.: 182 Otros:</p> <p>MAZDA 2.5 DIESEL</p>
---	--

	<p>EF-0675</p> <p>Øext.: 202 Øint.: 135 - 17 H.: 313 Otros:</p> <p>JOHN DEERE AT 35155</p>
---	---

	<p>EF-0667</p> <p>Øext.: 264 Øint.: 154 - 23 H.: 520 Otros:</p> <p>J. DEERE 8430, 8630, 8440, N° AR 70106 9600 MAXIMIZER USA SEC. EF-0668</p>
---	--

	<p>EF-0676</p> <p>Øext.: 203 Øint.: 126 - 13 H.: 190 Otros:</p> <p>HYUNDAI CAMION 28130-45010</p>
---	--

	<p>EF-0667/1</p> <p>Øext.: 264 Øint.: 154 - 23 H.: 520 Otros:</p> <p>KOMATSU 670 PRIMARIO</p>
---	--

	<p>EF-0677</p> <p>Øext.: 147 Øint.: 74 H.: 183 Otros:</p> <p>NISSAN 3.1 N° 1654625600</p>
---	--

	<p>EF-0668</p> <p>Øext.: 151 Øint.: 123 - 16 H.: 464 Otros:</p> <p>J. DEERE 8430, 8630, 8440, N° AR 70107 9600 MAXIMIZER USA PRIM. EF-0667</p>
---	---

	<p>EF-0678</p> <p>Øext.: 278 - 234 Øint.: 123 - 17 H.: 418 Otros:</p> <p>SAME N° 24249380 USA SEC. EF-0622</p>
---	---

	<p>EF-0669</p> <p>Øext.: 133 Øint.: 83 - 17 H.: 280 Otros:</p> <p>TOYOTA 17801-75010</p>
--	---

	<p>EF-0679</p> <p>Øext.: 307 Øint.: 197 H.: 473 Otros:</p> <p>INTERNACIONAL N° 1674320C1 USA SEC. EF-0680</p>
--	--

	<p>EF-0670</p> <p>Øext.: 264 Øint.: 153 H.: 238 Otros:</p> <p>CATERPILLAR 7N-1225</p>
---	--

	<p>EF-0680</p> <p>Øext.: 195 Øint.: 154 - 17 H.: 403 Otros:</p> <p>INTERNACIONAL N° 1674319C1 USA PRIM. EF-0679</p>
---	--

	<p>EF-0671</p> <p>Øext.: 302 Øint.: 148 - 17 H.: 400 Otros:</p> <p>IHC & WHITE TRUCKS CUMMINS 3022209 CATERPILLAR 7C-8327</p>
---	--

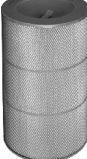
	<p>EF-0681</p> <p>Øext.: 307 Øint.: 197 - 23 H.: 543 Otros:</p> <p>TRACTOR AGCO N° 3633059M1 STAR USA SEC. EF-0682</p>
---	---

	<p>EF-0672</p> <p>Øext.: 121 Øint.: 42 H.: 308 Otros:</p> <p>ESPECIAL</p>
---	--

	<p>EF-0682</p> <p>Øext.: 195 Øint.: 154 - 17 H.: 520 Otros:</p> <p>TRACTOR AGCO N° 3632350M1 STAR USA PRIM. EF-0681</p>
---	--

	<p>EF-0673</p> <p>Øext.: 185 Øint.: 107 H.: 240 Otros:</p> <p>CATERPILLAR 7X-6345</p>
---	--

	<p>EF-0683</p> <p>Øext.: 180 - 133 Øint.: 66 - 17 H.: 292 Otros:</p> <p>AUTOELEVADOR KOMATSU 3EC 01 11630 USA SEC. EF-0523</p>
---	---

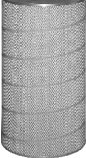
	<p>EF-0674</p> <p>Øext.: 324 Øint.: 212 - 10 H.: 618 Otros:</p> <p>COSECHADORA CLASS PICADORA JAGUAR 860-880</p>
---	---

	<p>EF-0684</p> <p>Øext.: 243 Øint.: 131 - 11 H.: 297 Otros:</p> <p>FIAT EUROARGO</p>
---	---

EF



EF-0685

Øext.: 307
Øint.: 196 - 17
H.: 521
Otros:

GM - DETROIT - IVECO 107030
FIAT HITACHI 1980900
USA SEC. EF-0686



EF-0686

Øext.: 214 - 184
Øint.: 155 - 17
H.: 488
Otros:

GM - DETROIT - IVECO 107030
FIAT HITACHI 1930901
USA PRIM. EF-0685



EF-0687

Øext.: 264
Øint.: 153
H.: 406
Otros:

CAMION M. BENZ L1620
N° 3760948104
LK 1218 KC,
MOTOR OM 366 A-LA 96



EF-0688

Øext.: 324
Øint.: 214 - 23
H.: 442
Otros:

WHITE 02-7088627
02-7074467 (TRUCKS)



EF-0689

Øext.: 210 - 205
Øint.: 190 - 17
H.: 608
Otros:

COSECHADORA CLASS
USA PRIM. EF-0674



EF-0690

Øext.: 237 - 189
Øint.: 120 - 17
H.: 391
Otros:

AUTOELEVADOR
KOMATSU 600-181-6550
HITACHI 4129907
CASE 9010 N° 161863A1
USA SEC. EF-0711



EF-0691

Øext.: 307
Øint.: 197
H.: 404
Otros:

VOLVO 22001-3205



EF-0692

Øext.: 230
Øint.: 122 - 10
H.: 503
Otros:

J. DEERE AR 82915, AR 57024
KOMATSU 1298058
C/MOTOR CUMMINS
NEW HOLLAND 279627
USA SEC. EF-0693



EF-0693

Øext.: 119
Øint.: 100 - 17
H.: 419
Otros:

J. DEERE AR 81313, AR 57025
KOMATSU 1298059
C/MOTOR CUMMINS
USA PRIM. EF-0692



EF-0694

Øext.: 217
Øint.: 110
H.: 146
Otros:

LAND CRUCIER 17801-68020,
17801-66030 DT- 4.2



EF-0695

Øext.: 265 - 219
Øint.: 135 - 24
H.: 452
Otros:

KOMATSU 600-181-6820,
600-181-6740
DAEWOO 24749053
USA SEC. EF-0696



EF-0696

Øext.: 132
Øint.: 106 - 17
H.: 413
Otros:

KOMATSU 600-181-6730
DAEWOO 24749054
USA PRIM. EF-0695



EF-0697

Øext.: 155
Øint.: 79
H.: 203
Otros:

ISUZU 3.1/1-970440226-0



EF-0698

Øext.: 264
Øint.: 153
H.: 416
Otros:

CAMION INTERNACIONAL;
IHC 476741 C1
USA SEC. EF-0715



EF-0699

Øext.: 151
Øint.: 123 - 17
H.: 391
Otros:

FIAT HITACHI FX250LC, N° 71421048
AGCO 46428600 / CNH 9965159
USA PRIM. EF-0749



EF-0700

Øext.: 318 - 294
Øint.: 153 - 15
H.: 417
Otros:

FIAT HITACHI FX250LC,
N° 71421050
USA SEC. EF-0699



EF-0701

Øext.: 318 - 264
Øint.: 153 - 15
H.: 417
Otros:

M. FERGUSON 3389793 M2,
COSECH. MF 34-38,
AGCO 46442300
USA SEC. EF-0699



EF-0702

Øext.: 217
Øint.: 110 - 32
H.: 120
Otros:

TOYOTA 4X4 2.8 D,
N° 17801-54170



EF-0703

Largo: 147 X 78
Ancho: 105 X 34 - 6
Alto: 57
Otros:

COMPACTADOR MIKASA
MT-86 D DIESEL





EF-0704

Øext.: 100 X 72
Øint.: 32 - 6
H.: 68
Otros:

VIBRADOR HERDS DIESEL
AFZE-18

	<p>EF-0705</p> <p>Øext.: 133 - 150 FORD D6NN 9601 B Øint.: 82 - 13 H.: 381 Otros:</p>
---	--

	<p>EF-0715</p> <p>Øext.: 151 CAMION INTERNACIONAL Øint.: 123 - 17 IHC 482644 C1 H.: 352 USA PRIM. EF-0698 Otros:</p>
---	---

	<p>EF-0706</p> <p>Øext.: 155 - 198 CAMION KIA K 3600 Øint.: 89 - 12 H.: 242 Otros:</p>
---	---

	<p>EF-0716</p> <p>Largo: 350 TRACTOR CASE 8920 Ancho: 175 (CABINA) Alto: 60 Otros:</p>
---	--

	<p>EF-0707</p> <p>Øext.: 215 - 185 FIAT ALLIS 70197588 Øint.: 157 - 17 USA PRIM. EF-0467 H.: 449 COLECTIVO (EL DETALLE) Otros: OA-105 USA PRIM. EF-0602</p>
---	---

	<p>EF-0717R</p> <p>Øext.: 322 - 300 SCANIA 104, N°1377098 Øint.: 182 (SERIE 98) H.: 522 Otros:</p>
---	--

	<p>EF-0708R</p> <p>Øext.: 127 - 118 CLARK GENESIS N° 902255802, Øint.: 82 2791707 / CATERPILLAR 134-8726 H.: 312 CASE 133720A1 / J.DEERE Am129028 Otros: CARCAZA PLASTICA FR-06 - USA EF-0903R</p>
---	--

	<p>EF-0718R</p> <p>Øext.: 182 - 175 SCANIA 1377200 Øint.: 152 USA PRIM. EF-0755R H.: 503 Otros:</p>
---	---

	<p>EF-0709</p> <p>Øext.: 197 - 133 TOYOTA 178062380071 Øint.: 71 - 17 (AUTOELEVADOR) H.: 293 Otros:</p>
--	---

	<p>EF-0719</p> <p>Øext.: 125 VALMET 240910 Øint.: 64 - 8 H.: 366 Otros:</p>
--	--

	<p>EF-0710</p> <p>Øext.: 265 - 220 CAMION ISUZU Øint.: 135 - 23 8-94430250-0 NPR- 4.3 H.: 340 Otros:</p>
---	--

	<p>EF-0720</p> <p>Øext.: 213 - 155 MASSEY FERGUSON 3515586 M1 Øint.: 89 - 15 3595503 M1 H.: 281 USA SEC. EF-0618 Otros:</p>
---	--

	<p>EF-0711</p> <p>Øext.: 116 - 145 PALA DAEWOO LC-220 Øint.: 88 - 17 CASE 9030-9010, N° 161862 A1 H.: 330 USA PRIM. EF-0690 Otros:</p>
---	---

	<p>EF-0721</p> <p>Øext.: 274 JOHN DEERE T-52223 Øint.: 167 - 23 CAMION NISSAN CPC-16 H.: 398 USA SEC. EF-0722 Otros:</p>
---	---

	<p>EF-0712</p> <p>Øext.: 155 CAMION 3 STAR Y YUEJIN Øint.: 72 CON MOTOR ISUZU H.: 244 Otros:</p>
---	--

	<p>EF-0722</p> <p>Øext.: 162 JOHN DEERE T-52224 Øint.: 134 - 17 CAMION NISSAN CPC-16 H.: 364 USA PRIM. EF-0721 Otros:</p>
---	--

	<p>EF-0713</p> <p>Øext.: 224 KIA (ASIA TOPIC) N° 1143512 Øint.: 132 - 13 H.: 101 Otros:</p>
---	--

	<p>EF-0723</p> <p>Øext.: 197 REF. M.F. / DEUTZ / CHEV. SILVERADO Øint.: 108,5 - 8 FORD RANGER H.: 227 USA SEC. EF-0724 Otros:</p>
---	--

	<p>EF-0714</p> <p>Øext.: 179 KIA 2400 (CAMION) Øint.: 112,5 - 8 H.: 160 Otros:</p>
---	---

	<p>EF-0724</p> <p>Øext.: 109 REF. M.F. / DEUTZ / CHEV. SILVERADO Øint.: 89,5 - 17 FORD RANGER H.: 224 USA PRIM. EF-0723 Otros:</p>
---	---

EF



EF-0725

Øext.: 245 - 215 NEW HOLLAND 82008606,
82001819
Øint.: 123 - 11
H.: 400 CNH 730400578
Otros: USA SEC. EF-0726



EF-0726

Øext.: 150,5 NEW HOLLAND 82008607
Øint.: 100 - 11 CNH 73400579
H.: 390 USA PRIM. EF-0725 o EF-0958
Otros:



EF-0727

Øext.: 215 - 155 NEW HOLLAND 1930605
Øint.: 88 - 16
H.: 340
Otros:



EF-0728

Øext.: 243 KOMATSU D-65
Øint.: 131 - 17 N° 600-181-2300
H.: 395 USA SEC. EF-0729
Otros:



EF-0729

Øext.: 129 KOMATSU D-65
Øint.: 97 - 17 N° 6112-83-7620
H.: 342 USA PRIM. EF-0728
Otros:



EF-0730R

Øext.: 237 FORD F3 HZ 9601 A / GM 15619013
Øint.: 131 CHEV. KODIAK CAMION N° 15696245
H.: 324 JOHN DEERE RE-34962
Otros: CAT. 3116 - USA SEC. EF-0731R



EF-0731R

Øext.: 133 - 126 FORD F3 HZ 9R500A
Øint.: 89 CHEV. KODIAK CAMION N° 12544542
H.: 305 JOHN DEERE RE-34963
Otros: USA PRIM. EF-0730R



EF-0732R

Øext.: 164 CAT. 1106326 / J. DEERE 310 E, N° AT 171853
Øint.: 92 DYNAPAC 374771 / CASE 6190627M1
H.: 353 CASE N° 222421-A1 / FIAT 1930589
Otros: NEW HOLLAND 86559431 / CARCAZA FR-08
USA SEC. EF-0733R



EF-0733R

Øext.: 86 - 92 CAT. 1106331 / DYNAPAC 374772
Øint.: 75 J. DEERE 310 E, N° AT 171854
H.: 340 CASE N° 222422-A1 / FIAT 1930590
Otros: N. HOLLAND 86559432 / CARCAZA FR-08
USA PRIM. EF-0732R o EF-0942R



EF-0734

Øext.: 155 MINIBUS METRO
Øint.: 85 - 12 YUEJIN MODELOS NUEVOS
H.: 273
Otros:



EF-0735R

Øext.: 137 AGCO 10209500 / J. DEERE KV16428
Øint.: 81 M. FERGUSSON N° 3540046-M1
H.: 328 FIAT FC 80 N° 1930587 / HYSTER
Otros: CNH 47135972 / N. HOLLAND 86982522
CASE 222425A1 / CARCAZA PLÁSTICA FR-07
USA SEC. EF-0736R



EF-0736R

Øext.: 83 - 77 AGCO 10209400 / J. D. AP33331
Øint.: 63 M. FERGUSSON N° 3540047-M1
H.: 318 FIAT FC 80 N° 1930588 / HYSTER
Otros: CASE 222429A1 / CNH 47135975
N. HOLLAND 86982523 / CAT. 123-2368
CARCAZA FR-07 / USA PRIM. EF-0735R



EF-0737

Øext.: 222 KIA PRIDE POP
Øint.: 154
H.: 45
Otros:

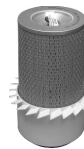

EF-0738

Øext.: 198 - 155 TORTONE 201 / CASE
Øint.: 89 - 19 INTERNACIONAL 3125342 RI
H.: 292
Otros:



EF-0739

Øext.: 104 - 85 TORTONE 201 / CASE
Øint.: 74 - 17 J.B.C./M.F./I. 3125255 RI
H.: 256
Otros:



EF-0740R

Øext.: 304 SCANIA 1421021 - 1335678
Øint.: 170 SERIE 4
H.: 524 USA SEC. EF-830R
Otros:



EF-0742R

Øext.: 207 INGERSOLL RAND 6800771
Øint.: 106 USA SEC. EF-0743R
H.: 382
Otros:



EF-0743R

Øext.: 107 - 102 INGERSOLL RAND 6800771
Øint.: 88 USA PRIM. EF-0742R
H.: 363
Otros:



















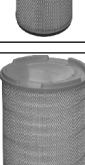

EF-0744R

Øext.: 207 INGERSOLL RAND 6734999
Øint.: 106 J.C.B. 32/912901
H.: 420 KOMATSU 600-158-3110
Otros: HAMM 2051200
USA SEC. EF-0745R



EF-0745R

Øext.: 107 - 102 INGERSOLL RAND 6734999
Øint.: 88 J.C.B. 32/912902
H.: 407 J. DEERE AT 203470
Otros: KOMATSU 600-185-3120
USA PRIM. EF-0744R y
EF-0746 R Carcaza Plástica FR-10

	<p>EF-0746R</p> <p>Øext.: 207 JOHN DEERE A1203469 Øint.: 106 CAT. 130-4678/ 1527217 H.: 418 USA SEC. EF-0745R Otros: Carcaza Plást. FR-10</p>
	<p>EF-0747R</p> <p>Øext.: 281 CASE N° 132151A1 / J. D. AT 203050 Øint.: 148 USA SEC. EF-0748R H.: 548 Otros:</p>
	<p>EF-0748R</p> <p>Øext.: 151 CASE N° 132149A1 / J. D. AT 203051 Øint.: 111 USA PRIM. EF-0749R H.: 536 Otros:</p>
	<p>EF-0749</p> <p>Øext.: 318 - 394 FIAT HITACHI Øint.: 153 EXCAVADORA 700052343 H.: 417 CNH 9965158 Otros: USA SEC. EF-0699</p>
	<p>EF-0750</p> <p>Øext.: 307 - 394 CUMMINS - GMC -IHC Øint.: 197 - 16 H.: 366 Otros:</p>
	<p>EF-0751R</p> <p>Øext.: 280 J. DEERE RE-51629 Øint.: 148 CAMION DIMEX 1625/ 1619/ 1418 H.: 396 AGCO 4278631M1 Otros: USA SEC. EF-0752R</p>
	<p>EF-0752R</p> <p>Øext.: 151,5 J. DEERE RE-51630 Øint.: 110 CAMION DIMEX 1625/ 1619/ 1418 H.: 383 AGCO 4270018M1 Otros: USA PRIM. EF-0751R</p>
	<p>EF-0753</p> <p>Øext.: 317 WORTHINGTON ELM64 Øint.: 191 - 11 USA SEC. EF-0754 H.: 536 Otros:</p>
	<p>EF-0754</p> <p>Øext.: 186 WORTHINGTON ELM89 Øint.: 155 - 19,5 USA PRIM. EF-0753 H.: 504 Otros:</p>
	<p>EF-0755R</p> <p>Øext.: 314 - 302 SCANIA N° 1423414 Øint.: 182 USA SEC. EF-0718R H.: 532 Otros:</p>
	<p>EF-0756R</p> <p>Øext.: 137 CASE 128781A1 - 128581A Øint.: 82 USA SEC. EF-0757R H.: 392 Otros:</p>
	<p>EF-0757R</p> <p>Øext.: 84 - 77 CASE 128782A1 - 128582A Øint.: 63 USA PRIM. EF-0756R H.: 377 Otros:</p>
	<p>EF-0758</p> <p>Øext.: 302 IHC TRUCKS Øint.: 148 - 17 H.: 449 Otros:</p>
	<p>EF-0759R</p> <p>Øext.: 280 J. DEERE AT-175223 Øint.: 151 CAT 1421339 H.: 525 VOLVO 11110022 Otros: USA SEC. EF-0760R</p>
	<p>EF-0760R</p> <p>Øext.: 143 - 151,5 J. DEERE AT-175224 Øint.: 110 CAT 1421404 H.: 501 VOLVO 11110023 Otros: USA PRIM. EF-0759R</p>
	<p>EF-0761</p> <p>Øext.: 165 RANGER TDIC MAXION 2.5 Øint.: 86 - 8 CARCAZA CP-585 H.: 256 USA SEC. EF-0841 Otros:</p>
	<p>EF-0762R</p> <p>Øext.: 237 CATERPILLAR 131-8822 Øint.: 131 EXCAVADORA CAT. 325 B H.: 344 USA SEC. EF-0763R Otros:</p>
	<p>EF-0763R</p> <p>Øext.: 126 - 133 CATERPILLAR 131-8821 Øint.: 94 EXCAVADORA CAT. 325B H.: 323 USA PRIM. EF-0762R Otros:</p>
	<p>EF-0764</p> <p>Øext.: 264 JOHN DEERE 770 A / AT 75035 Øint.: 153 - 17 USA SEC. EF-0765 H.: 340 Otros:</p>
	<p>EF-0765</p> <p>Øext.: 151 JOHN DEERE 770 A / AT 75036 Øint.: 123 - 17 USA PRIM. EF-0764 H.: 290 Otros:</p>

EF



EF-0767R

Øext.: 200 MERCEDES BENZ 712C/914C ELECTRÓNICO
 Øint.: 95 OM9042/2A PRIMARIO 374-094-71-04
 H.: 387
 Otros:



EF-0769R

Øext.: 155 FIAT IVECO 503106012
 Øint.: 83 TURBO DAILY 4910 - PRIMARIO
 H.: 341
 Otros:



EF-0770R

Øext.: 240 AGCO OPTIMA 550 Nº 054709-R1
 Øint.: 148 USA SEC. EF-0771R
 H.: 545
 Otros:



EF-0771R

Øext.: 135 - 138 AGCO OPTIMA 550 Nº 054710-R1
 Øint.: 123 USA PRIM. EF-0770R
 H.: 522
 Otros:



EF-0772

Øext.: 210 FORD 14000 C/MOTOR CUMMINS
 Øint.: 135 - 17 (FORD BF9T-9601-AA)
 H.: 320 USA SEC. EF-0773
 Otros:



EF-0773

Øext.: 140 FORD 14000 C/MOTOR CUMMINS
 Øint.: 115 - 17 (FORD BF9TSR-500-AA)
 H.: 296 USA PRIM. EF-0772
 Otros:



EF-0774

Øext.: 158 - 108 MITSUBISHI 91361-13300
 Øint.: 60 CATERPILLAR 108-5330
 H.: 230
 Otros:



EF-0775R

Øext.: 324 - 302 SCANIA 1377099- B 015061
 Øint.: 184 USA SEC. EF-0776R
 H.: 443
 Otros:



EF-0776R

Øext.: 182 - 177 SCANIA 1377201- B 015061
 Øint.: 154 USA PRIM. EF-0775R
 H.: 422
 Otros:



EF-0777

Øext.: 116 J. DEERE AT-31227 / AT-27823
 Øint.: 88 - 17 MF-3385731-M1
 H.: 285 USA PRIM. EF-0675
 Otros:



EF-0778

Øext.: 197 ZANELLO Nº 1721021
 Øint.: 112
 H.: 468
 Otros:



EF-0779R

Øext.: 148 JCB 32/915802
 Øint.: 88,5 CARGADORA MAXION Perkins SMSD-310
 H.: 361 MF-055119R1
 Otros: USA SEC. EF-0780R



EF-0780R

Øext.: 76,5 - 74,1 DEUTZ - PERKINS
 Øint.: 63,1 MF-055120R1
 H.: 340 JCB 32/915801
 Otros: USA PRIM. EF-0779R



EF-0781R

Øext.: 280 CATERPILLAR 6I 2501
 Øint.: 148 USA SEC. EF-0782R
 H.: 340
 Otros:



EF-0782R

Øext.: 149 CATERPILLAR 6I 2502
 Øint.: 105 USA PRIM. EF-0781R
 H.: 315
 Otros:



EF-0783R

Øext.: 125 CHEVROLET BLAZER NAFTERA 2.2 i
 Øint.: 79 SILVERADO S10 2.2 MPFI, GM 93 276 069
 H.: 320 SILVERADO S10 MWM DIESEL
 Otros: VOLKSWAGEN 2171296201 USA SEC. EF-0784R



EF-0784R

Øext.: 65 SILVERADO S10 MWM DIESEL
 Øint.: 53 G.M. - MASSEY FERGUSON
 H.: 302 USA PRIM. EF-0783R
 Otros:



EF-0785R

Øext.: 291 CATERPILLAR 980F - 826G - 825G
 Øint.: 182 Nº 6I-0273
 H.: 342 USA SEC. EF-0786R
 Otros:



EF-0786R

Øext.: 185 - 173 CATERPILLAR 980F - 826G - 825G
 Øint.: 126 Nº 6I-0274
 H.: 337 USA PRIM. EF-0785R
 Otros:



EF-0787R

Øext.: 330 MOTORCRAFT FA-1077
 Øint.: 173 DETROIT 60 SERIES
 H.: 388
 Otros:



EF-0789R
 Øext.: 232 CATERPILLAR 61-2499
 Øint.: 120 USA SEC. EF-0790R
 H.: 318
 Otros:



EF-0799
 Øext.: 132 CASE A43265
 Øint.: 106 - 17 J. DEERE AR-45785
 H.: 285 TRACTOR J. DEERE 5020
 Otros:



EF-0790R
 Øext.: 119 - 111 CATERPILLAR 61-2500
 Øint.: 120 USA PRIM. EF-0789R
 H.: 318
 Otros:



EF-0800R
 Øext.: 83,5 - 79 FILTRO SEC.
 Øint.: 63,5 (REEMP. AL EF-0736R,
 H.: 320 USA PRIM. EF-0735R)
 Otros: CIERRE CÓNICO



EF-0791R
 Øext.: 330 INTERNACIONAL NAVISTAR 200 5895 C1
 Øint.: 173 COSECHADORA INTERNACIONAL
 H.: 473 COSECHADORA JOHN DEERE 9610
 Otros: AÑO 2000 => - Nº RE-63931



EF-0801R
 Øext.: 207 AUTOELEVADOR DAEWOO
 Øint.: 106 D-141107 / CAT. 61-1450
 H.: 166
 Otros:



EF-0792R
 Øext.: 175 J. DEERE RE-63931 / 63932
 Øint.: 165 INTERNACIONAL 2022289 C1
 H.: 450
 Otros:



EF-0802R
 Øext.: 108 - 100 AUTOELEVADOR DAEWOO
 Øint.: 88 D-141106 / CAT. 61-1451
 H.: 146
 Otros:



EF-0793R
 Øext.: 192 AGCO 055129R1 - 6.150 - M. F. 297
 Øint.: 113 SINCRO-AGRALE - DEUTZ MA 7.5T
 H.: 398 CASE 149167A1
 Otros: USA SEC. EF-0794R



EF-0803
 Øext.: 100 - 170 CATERPILLAR 7W-6754
 Øint.: 60 (USA PRIM. LAF-1820)
 H.: 134
 Otros:



EF-0794R
 Øext.: 105 - 107 AGCO 055130R1 - 6.150 M. F. 297
 Øint.: 93,5 SINCRO-AGRALE - DEUTZ MA 7.5T
 H.: 380 CASE 149166A1
 Otros: USA PRIM. EF-0793R



EF-0804R
 Øext.: 312 RENAULT Nº 5010230916
 Øint.: 179 (USA SEC. EF-0805R)
 H.: 554
 Otros:



EF-0795
 Largo: 495 PANEL AIRE CABINA
 Ancho: 190 TRACTOR VALMET 1880 S
 Alto: 60
 Otros:



EF-0805R
 Øext.: 178 - 173 RENAULT Nº 5010269584
 Øint.: 144 (USA PRIM. EF-0804R)
 H.: 533
 Otros:



EF-0796R
 Øext.: 330 CASE Nº 243968 A1
 Øint.: 173 USA SEC. EF-0797R
 H.: 568
 Otros:



EF-0806R
 Øext.: 312 TEREX Nº 15270188
 Øint.: 179 CAMIÓN ASTRA
 H.: 523 (USA SEC. EF-0807R)
 Otros:



EF-0797R
 Øext.: 174 - 165 CASE Nº 243969 A1
 Øint.: 133 USA PRIM. EF-0796R
 H.: 546
 Otros:



EF-0807R
 Øext.: 178 - 173 TEREX Nº 15270189
 Øint.: 144 VOLVO 11033997 - CAMIÓN ASTRA
 H.: 506 CUMMINS - CAT. - EQUIPOS J. DEERE
 Otros: (USA SEC. EF-0806R)



EF-0798
 Øext.: 202 - 255 A. CHALMERS 654409
 Øint.: 135 - 17 KOMATSU 381-924279-1
 H.: 416 ISUZU 9-14215-184-0
 Otros:



EF-0808R
 Øext.: 312 RENAULT Nº 5010230841
 Øint.: 179 SCANIA 1387549
 H.: 468 USA SEC. EF-0809R
 Otros:

EF



EF-0809R

Øext.: 178 - 173 RENAULT 5010317187
 Øint.: 144 USA PRIM. EF-0808R
 H.: 443
 Otros:



EF-0819

Øext.: 240 TOYOTA 17801-67070
 Øint.: 108,5
 H.: 119 - 120
 Otros:



EF-0810

Øext.: 405 - 360 FILTRO MOTOR ELÉCTRICO
 Øint.: 205 FARR-72518004
 H.: 684
 Otros:



EF-0820R

Øext.: 352 - 331 VOLVO N° 8149961 - 3162322
 Øint.: 221 - 200
 H.: 414
 Otros:



EF-0811R

Øext.: 316 CATERPILLAR 61-2509
 Øint.: 208 USA SEC. EF-0812R
 H.: 484
 Otros:

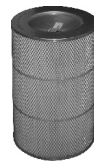

EF-0822

Øext.: 252 CASE A171255
 Øint.: 154 - 17 USA SEC. EF-0823
 H.: 417
 Otros:



EF-0812R

Øext.: 210 - 200 CATERPILLAR 61-2510
 Øint.: 145 USA PRIM. EF-0811R
 H.: 386
 Otros:



EF-0823

Øext.: 151 CASE A171256
 Øint.: 123 - 17 USA PRIM. EF-0822
 H.: 368
 Otros:



EF-0813R

Øext.: 342 CATERPILLAR D-9 N° 165-1689
 Øint.: 208 USA SEC. EF-0814R
 H.: 396
 Otros:



EF-0824

Øext.: 213,5 CATERPILLAR 7N-9028
 Øint.: 103,5 8N-5504
 H.: 148
 Otros:



EF-0814R

Øext.: 210 - 200 CATERPILLAR 61-2508
 Øint.: 145 USA PRIM. EF-0813R
 H.: 298
 Otros:



EF-0826

Øext.: 307 JOHN DEERE AR-95758
 Øint.: 198 - 23 USA SEC. EF-0827
 H.: 496
 Otros:



EF-0815

Øext.: 302 VOLVO 90610052/VF 160 A
 Øint.: 182 - 11
 H.: 329 -341
 Otros:



EF-0827

Øext.: 185 JOHN DEERE AR-95759
 Øint.: 156 - 17 USA PRIM. EF-0826
 H.: 470
 Otros:



EF-0816R

Øext.: 195 HYUNDAI 28130-45020
 Øint.: 129
 H.: 194 - 217
 Otros:



EF-0828

Øext.: 318 CATERPILLAR 1P8483 - 8N5313
 Øint.: 232 USA SEC. EF-0829
 H.: 392
 Otros:



EF-0817R

Øext.: 195 HYUNDAI 28130-54000
 Øint.: 129
 H.: 252 - 275
 Otros:



EF-0829

Øext.: 219 - 290 CATERPILLAR 1P8482 - 7N1306
 Øint.: 178 USA PRIM. EF-0828
 H.: 382
 Otros:



EF-0818

Øext.: 198 - 155 SULLAIR 022 500 44-537
 Øint.: 99,5 - 17
 H.: 316
 Otros:





EF-0830R

Øext.: 169 - 161 SCANIA 1335680
 Øint.: 130 USA PRIM. EF-0740R
 H.: 500
 Otros:

	<p>EF-0831</p> <p>Øext.: 197 - 107 VOLVO 823701 - 3825778 Øint.: 98 MODELO TAMD 60 / TAMD 70 H.: 720 - 668 Otros:</p>
---	---

	<p>EF-0841</p> <p>Øext.: 91 - 80 CARCAZA CP-585 Øint.: 69 - 17 USA PRIM. EF-0761 H.: 253 Otros:</p>
---	---

	<p>EF-0832</p> <p>Øext.: 121 ZANELLO 1721022 Øint.: 100 - 17 H.: 454 Otros:</p>
---	---

	<p>EF-0842</p> <p>Øext.: 303 GMC-15527863 Øint.: 170 - 27 H.: 550 Otros:</p>
---	--

	<p>EF-0833</p> <p>Øext.: 85 DAEWO 24749014 Øint.: 57 - 16 JOHN DEERE TH-106446 H.: 338 KOMATSU 300-181-9500 Otros:</p>
---	--

	<p>EF-0843</p> <p>Øext.: 242 FRAIGHTLINER MACK Øint.: 165 GMC 25043068 H.: 723 Otros:</p>
---	---

	<p>EF-0834R</p> <p>Øext.: 156 AGCO 82642100 Øint.: 97 NISSAN ECO T-100/54 3.0 H.: 376 M. FERGUSON 292-055124R1 Otros: GM 93367976 -SILVERADO-6,125 USA SEC. EF-0835R</p>
---	--

	<p>EF-0844R</p> <p>Øext.: 240 - 214 VOLVO TAD/TWD 740 GE Øint.: 123 H.: 446 Otros:</p>
---	--

	<p>EF-0835R</p> <p>Øext.: 87 AGCO 82642000 / NISSAN Øint.: 72 M. FERGUSON 292-055125R1 H.: 360 USA PRIM. EF-834 R Otros:</p>
--	--

	<p>EF-0845</p> <p>Largo: 190 PANEL CABINA ALLIS 134692 Ancho: 55 CASE / NEW HOLLAND 70569300 Alto: 711 Otros:</p>
---	---

	<p>EF-0836R</p> <p>Øext.: 216 AGCO 82612300 Øint.: 127 M. FERGUSON 055134R1 (COSECHADORA 5650 H.: 402 ADVANCE C/ MOTOR CUMMINS Otros: MOTOR PERKINS LINEA 1000 / VALMET1380 USA SEC. EF-0837R</p>
---	---

	<p>EF-0846</p> <p>Øext.: 307 J. DEERE PICADORA AZ-45868 Øint.: 197 - 17 USA SEC. EF-0847 H.: 572 Otros:</p>
---	---

	<p>EF-0837R</p> <p>Øext.: 115 AGCO 82612200 Øint.: 104 M. FERGUSON 055135R1 H.: 380 VALMET 1380 Otros: USA PRIM. EF-0836R</p>
---	---

	<p>EF-0847</p> <p>Øext.: 185 - 215 J. DEERE PICADORA AZ-45867 Øint.: 157 - 16 USA PRIM. EF-0846 H.: 552 Otros:</p>
---	--

	<p>EF-0838</p> <p>Øext.: 351 E-376094 (ALUAR) Øint.: 241 H.: 770 Otros:</p>
---	---

	<p>EF-0848R</p> <p>Øext.: 315 CATERPILLAR 61-2507 Øint.: 210 H.: 393 Otros:</p>
---	---

	<p>EF-0839R</p> <p>Øext.: 137 TOYOTA 17743-23600-71 Øint.: 82 USA SEC. 0970R H.: 280 Otros:</p>
---	---

	<p>EF-0849</p> <p>Øext.: 273 GUASCOR 7650011 Øint.: 210 H.: 155 Otros:</p>
---	--

	<p>EF-0840R</p> <p>Øext.: 169 RANGER CON MOTOR MAXION Øint.: 94,5 - 92,5 MOTORCRAFT RFA-30 H.: 293 Otros:</p>
---	---

	<p>EF-0850</p> <p>Øext.: 273 GUASCOR 7650014 Øint.: 210 H.: 280 Otros:</p>
---	--

EF

	<p>EF-0851R</p> <p>Øext.: 164 CHEVROLET - GM Trucks Øint.: 92 H.: 278 Otros:</p>
	<p>EF-0852R</p> <p>Øext.: 262 FORD CARGO 1722 Øint.: 149 Mod. 2002-RFA 38 H.: 408 VW 250129620 Otros: USA SEC. EF-0870R</p>
	<p>EF-0853</p> <p>Øext.: 162 - 149 FILTRO CÓNICO Øint.: 81 SAME 2-4249-340-1 H.: 315 N. HOLLAND 1930443 TRACTOR 55,86 Otros: USA SEC. EF-0854</p>
	<p>EF-0854</p> <p>Øext.: 92 - 50 FILTRO CÓNICO Øint.: 62 - 17 SAME 2-4249-340-2 H.: 285 NEW HOLLAND 1930442 TRACTOR 55,86 Otros: USA PRIM. EF-0853</p>
	<p>EF-0855</p> <p>Øext.: 290 - 219 CATERPILLAR 6N6444 Øint.: 178 CAT. 3406 - 3408 H.: 305 MOTOR INDUSTRIAL MARINO Otros: USA PRIM. EF-0828</p>
	<p>EF-0856R</p> <p>Øext.: 127 SVEDALA 380295 Øint.: 84 USA SEC. EF-0857R H.: 246 Otros:</p>
	<p>EF-0857R</p> <p>Øext.: 79 SVEDALA 380294 Øint.: 64 USA PRIM. EF-0856R H.: 226 Otros:</p>
	<p>EF-0858R</p> <p>Øext.: 206 CATERPILLAR 108-0671 Øint.: 108 USA SEC. EF-0859R H.: 296 Otros:</p>
	<p>EF-0859R</p> <p>Øext.: 102 CATERPILLAR 108-0672 Øint.: 69 USA PRIM. EF-0858R H.: 269 Otros:</p>
	<p>EF-0860R</p> <p>Øext.: 235 J. DEERE 670 CH / AT-178516 Øint.: 131 CASE 249987A1 H.: 481 KOMATSU 6001854110 Otros: DOOSAN 4740004 USA SEC. EF-0861R</p>
	<p>EF-0861R</p> <p>Øext.: 126 - 133 J. DEERE 670 CH / AT-178517 Øint.: 96 CASE 249988A1 H.: 465 KOMATSU 6001854120 Otros: DOOSAN 47400039 USA PRIM. EF-0860R</p>
	<p>EF-0862R</p> <p>Øext.: 235 CARGADORA VOLVO L90E Øint.: 131 Nº 11110175 / JCB 32925404 H.: 473 USA SEC. EF-0863R Otros:</p>
	<p>EF-0863R</p> <p>Øext.: 126 - 133 CARGADORA VOLVO L90E Øint.: 96 Nº 11110176 / JCB 32925405 H.: 454 USA PRIM. EF-0862R Otros:</p>
	<p>EF-0864R</p> <p>Øext.: 174 IVECO 9382-8280 Øint.: 106 H.: 423 Otros:</p>
	<p>EF-0865R</p> <p>Øext.: 205 FORD CARGO 1517 Øint.: 132 H.: 430 Otros:</p>
	<p>EF-0867R</p> <p>Øext.: 294 AGCO 054707R1 Øint.: 203 ALTERNATIVO EF-0969R H.: 594 Otros:</p>
	<p>EF-0868R</p> <p>Øext.: 196 - 193 COSECH. AGCO MS38 y Mf38 Øint.: 186 Nº 054708R1 H.: 566,5 COSECH. AGCO ALLIS OPTIMA 650 Otros: C/MOTOR CUMMINS Y DEUTZ</p>
	<p>EF-0869R</p> <p>Øext.: 265 M. BENZ 4760940004 Øint.: 170 SCANIA 1485592 H.: 533 VOLVO 20544738 Otros:</p>
	<p>EF-0870R</p> <p>Øext.: 137 - 144,5 FORD CARGO 1722 Øint.: 112,5 MOD. 2002 H.: 423 R/FA/ 40 Otros: USA PRIM. EF-0852R</p>
	<p>EF-0871</p> <p>Øext.: 191 - 264 FORD D8HZ-9601-B Øint.: 100 - 176 GMC 8997222 H.: 736 INTERNACIONAL 526059-C91 Otros:</p>



EF-0872
 Øext.: 307
 Øint.: 197 - 17
 H.: 633
 Otros:
 PERLINI 350087A
 USA SEC. EF-0873



EF-0882
 Øext.: 275
 Øint.: 133 - 10
 H.: 574
 Otros:
 NEW HOLLAND 84994418



EF-0873
 Øext.: 185 - 215
 Øint.: 157 - 16
 H.: 600
 Otros:
 PERLINI 350088A
 USA PRIM. EF-0872



EF-0883R
 Øext.: 105
 Øint.: 60
 H.: 278
 Otros:
 AUTOELEVADOR C/ MOTOR
 NISSAN MCF91B6100912



EF-0874
 Largo: 647
 Ancho: 496
 Alto: 65
 Otros:
 WAUKESHA 169180 K
 GUASCOR 1835002



EF-0884
 Øext.: 110
 Øint.: 50 - 8
 H.: 226
 Otros:
 LINDE 0009839012



EF-0875R
 Øext.: 131,5
 Øint.: 65
 H.: 298
 Otros:
 LINDE 0009839000
 USA SEC. EF-0876R



EF-0885
 Øext.: 125
 Øint.: 63 - 8
 H.: 292
 Otros:
 LINDE 0009839013



EF-0876R
 Øext.: 64
 Øint.: 53
 H.: 279,5
 Otros:
 LINDE 0009839001
 USA PRIM. EF-0875R



EF-0886
 Øext.: 324
 Øint.: 212 - 11
 H.: 479
 Otros:
 IVECO 2992374 - 41272211
 USA SEC. EF-0887



EF-0877
 Øext.: 164
 Øint.: 86 - 8
 H.: 311
 Otros:
 CHEVROLET S-10 (REFORMA)
 USA SEC. EF-0878



EF-0887
 Øext.: 203
 Øint.: 189 - 17
 H.: 460
 Otros:
 IVECO 450-37 EURO TECH
 DOBLE DIFERENCIAL Nº 41214149
 USA PRIM. EF-0886



EF-0878
 Øext.: 90,5
 Øint.: 69 - 17
 H.: 294
 Otros:
 CHEVROLET S-10 (REFORMA)
 USA PRIM. EF-0877



EF-0888
 Largo: 495
 Ancho: 495
 Alto: 135
 Otros:
 WAUKESHA 169180 N



EF-0879
 Øext.: 200 - 214
 Øint.: 87 - 16
 H.: 392
 Otros:
 JOHN DEERE DDX 18911
 USA SEC. EF-0490



EF-0889R
 Øext.: 316
 Øint.: 208
 H.: 393
 Otros:
 CATERPILLAR 612505
 USA SEC. EF-0890R



EF-0880
 Øext.: 282
 Øint.: 170 - 17
 H.: 389
 Otros:
 RENAULT (RVI) 5000751674 M
 5010094196
 USA SEC. EF-0908



EF-0890R
 Øext.: 209 - 200
 Øint.: 145
 H.: 375
 Otros:
 CATERPILLAR 612506
 USA PRIM. EF-0889R



EF-0881
 Øext.: 252
 Øint.: 120
 H.: 665 - 700
 Otros:
 VOLVO Nº 3826215-0



EF-0891
 Øext.: 255 - 202
 Øint.: 135 - 13
 H.: 350
 Otros:
 JOHN DEERE
 DQ-46907 - DQ-59009
 TRACTOR 7505 - 6605
 USA SEC. EF-0892

EF



EF-0892

Øext.: 116 - 145
 Øint.: 87 - 13
 H.: 320
 Otros:

JOHN DEERE
 DQ-46908 - DQ-59010
 TRACTOR 7505 - 6605
 USA PRIM. EF-0891



EF-0893

Øext.: 368 - 324
 Øint.: 212 - 24
 H.: 368
 Otros:

CATERPILLAR 4S-8337
 USA SEC. EF-0461



EF-0894R

Øext.: 280
 Øint.: 148
 H.: 415
 Otros:

CATERPILLAR 6I-2503
 KOMATSU 6001855100
 USA SEC. EF-0895R



EF-0895R

Øext.: 149
 Øint.: 105
 H.: 387
 Otros:

CATERPILLAR 6I-2504
 KOMATSU 6001855100
 USA PRIM. EF-0894R



EF-0896

Øext.: 417 - 306
 Øint.: 197
 H.: 602
 Otros:

NELSON 64288 P



EF-0897

Øext.: 150 - 133
 Øint.: 82 - 12
 H.: 297
 Otros:

FORD D6NN-9601-A
 FORD TRACTORES
 NEW HOLLAND



EF-0898R

Øext.: 223
 Øint.: 121
 H.: 175
 Otros:

TOYOTA 3000
 200617801-0C010



EF-0899

Øext.: 220 - 185
 Øint.: 94,5 - 12
 H.: 336
 Otros:

NEW HOLLAND
 73401701 - 82027153
 TRACTOR TS-90/TS100/TS110
 USA SEC. EF-0900



EF-0900

Øext.: 112 - 91,5
 Øint.: 76,2 - 12
 H.: 290
 Otros:

NEW HOLLAND
 73401703 - 82008601
 TRACTOR TS-90/TS100/TS110
 USA PRIM. EF-0899



EF-0901R

Øext.: 160
 Øint.: 98
 H.: 268
 Otros:

FORD RANGER 3.0
 MOD.2006
 UOUKA 5L55-9601-AA



EF-0902R

Øext.: 127
 Øint.: 82
 H.: 307
 Otros:

AUTOELEVADOR JUNGHEINRICH
 NELSON 87797M
 AUTOELEVADOR HANGCHA 2.5-3TN



EF-0903R

Øext.: 81
 Øint.: 63
 H.: 299
 Otros:

CASE-133421A1
 BORCAT-6666334
 KUBOTA R2401-42281
 FR-06 SECUNDARIO



EF-0904R

Øext.: 330
 Øint.: 172
 H.: 579 - 591
 Otros:

JOHN DEERE AH164062
 DC 090V
 USA SEC. EF-0905R



EF-0905R

Øext.: 164,5 - 175
 Øint.: 132,5
 H.: 566 - 571,5
 Otros:

JOHN DEERE
 AH164063 - DC 3165
 USA PRIM. EF-0904R



EF-0906R

Øext.: 303
 Øint.: 187,5
 H.: 465 - 487
 Otros:

VOLVO PENTA (TAD 1642)
 N° GE-3827643



EF-0907

Øext.: 352 - 282
 Øint.: 171 - 17
 H.: 380 - 392
 Otros:

JOY COMPRESORES
 N° 519002
 (PRIMARIO)



EF-0908

Øext.: 192 - 162
 Øint.: 134 - 17
 H.: 380
 Otros:

JOY COMPRESORES
 N° 3606283-21
 USA PRIM. EF-0880



EF-0909R

Øext.: 360 - 312
 Øint.: 227,5
 H.: 631
 Otros:

JOHN DEERE AH-170798
 N. HOLLAND 84432503
 84819117
 USA SEC. EF-0910R



EF-0910R

Øext.: 219 - 230,5
 Øint.: 176,5
 H.: 623
 Otros:

JOHN DEERE AH-174196
 N. HOLLAND 84432504
 USA PRIM. EF-0909R





EF-0911

Øext.: 260
 Øint.: 167 - 13
 H.: 430
 Otros:

MOTONIVELADORA
 TIANGONG PY 160G
 N° K-2642
 USA SEC. EF-0912.

	<p>EF-0912</p> <p>Øext.: 162 Øint.: 127 - 13 H.: 380 Otros:</p>	<p>MOTONIVELADORA TIANGONG PY 160G USA PRIM. EF-0911</p>
---	--	--

	<p>EF-0922</p> <p>Øext.: 162 Øint.: 107 - 13 H.: 362 Otros:</p>	<p>PALA CARGADORA TIANGONG MOD.ZL-50 CHENG-GONG.MG 1320 USA PRIM. EF-0921</p>
---	--	---

	<p>EF-0913</p> <p>Øext.: 235 Øint.: 135 - 12 H.: 430 Otros:</p>	<p>PALA CARGADORA ZL-30F-1 9103-0604260251 MICHIGAN MM165 USA SEC. EF-0914</p>
---	--	--

	<p>EF-0923</p> <p>Øext.: 454 - 448 Øint.: 311 - 23 - 13 H.: 496 Otros:</p>	<p>CAMION TEREX 33.07 USA SEC. EF-0924</p>
---	---	--

	<p>EF-0914</p> <p>Øext.: 148 - 132 Øint.: 102 - 12 H.: 413 Otros:</p>	<p>PALA CARGADORA ZL-30F-1 MICHIGAN Mm165 USA PRIM. EF-0913</p>
---	--	---

	<p>EF-0924</p> <p>Øext.: 302 Øint.: 257 - 25 H.: 460 Otros:</p>	<p>CAMION TEREX 33.07 USA PRIM. EF-0923</p>
---	--	---

	<p>EF-0915</p> <p>Øext.: 307 Øint.: 197 - 17 H.: 555 Otros:</p>	<p>PALA CARG. HYUNDAI (R4500LC-3A / R4500LC-7/ HL770-3) N°14L1-01560 USA SEC. EF-0916</p>
---	--	---

	<p>EF-0925</p> <p>Øext.: 260 Øint.: 167 - 17 H.: 411 Otros:</p>	<p>RODILLO NEUMÁTICO TIANGONG MOD. ZL-26 USA SEC. EF-0926</p>
---	--	---

	<p>EF-0916</p> <p>Øext.: 194 Øint.: 154 - 17 H.: 530 Otros:</p>	<p>PALA CARG. HYUNDAI (R4500LC-3A / R4500LC-7/ HL770-3) N° 14L1-01570 USA PRIM. EF-0915</p>
--	--	---

	<p>EF-0926</p> <p>Øext.: 162 Øint.: 133 - 17 H.: 363 Otros:</p>	<p>RODILLO NEUMÁTICO TIANGONG MOD. ZL-26 USA PRIM. EF-0925</p>
--	--	--

	<p>EF-0917</p> <p>Øext.: 202 - 255 Øint.: 135 - 19 H.: 502 Otros:</p>	<p>RETRO-ESC.HYUNDAI (ROBEX 210 LC-7) N° 11EM-21041 USA SEC. EF-0918</p>
---	--	--

	<p>EF-0926/1</p> <p>Øext.: 162 Øint.: 133 - 13 H.: 363 Otros:</p>	<p>DOWEL -MICHIGAN R95C MOTOR HANOMAG USA PRIM. EF-0921</p>
---	--	---

	<p>EF-0918</p> <p>Øext.: 130 Øint.: 104 - 19 H.: 492 Otros:</p>	<p>RETROEXC. HYUNDAI (ROBEX 210 LC-7) N° 11EM-21051 USA PRIM. EF-0917</p>
---	--	---

	<p>EF-0927R</p> <p>Øext.: 235 Øint.: 133 H.: 368 Otros:</p>	<p>NISSAN 16546Z9018 USA SEC. EF-0979R</p>
---	--	--

	<p>EF-0919</p> <p>Øext.: 265 Øint.: 133 H.: 229 Otros:</p>	<p>ATLAS COPCO 2900.1007.00</p>
---	---	---------------------------------

	<p>EF-0928R</p> <p>Øext.: 275 Øint.: 174 H.: 373 Otros:</p>	<p>NISSAN CAMION CONDOR JUNIOR 16546-Z9100</p>
---	--	--

	<p>EF-0920</p> <p>Øext.: 61 - 116 Øint.: 51 - 17 H.: 336 Otros:</p>	<p>CASE D 82775 JOHN DEERE MG 272744 NEW HOLLAND 221688 USA PRIM. EF-0485</p>
---	--	---

	<p>EF-0930</p> <p>Øext.: 153 - 103 Øint.: 63 - 17 H.: 265 Otros:</p>	<p>JOHN DEERE TRACTORES JOHN DEERE M802606</p>
---	---	--

	<p>EF-0921</p> <p>Øext.: 260 Øint.: 167 - 13 H.: 410 Otros:</p>	<p>PALA CARG. TIANGONG MOD.ZL-50 MICHIGAN R95C MOTOR HANOMAG CHENG-GONG.MG 1320 USA SEC. EF-0922</p>
---	--	--

	<p>EF-0932R</p> <p>Øext.: 89 Øint.: 46,5 H.: 187 Otros:</p>	<p>FILTRO PRIM. DE CARCAZA FR-04 JOHN DEERE M113621 KUBOTA USA SEC. EF-0933R</p>
---	--	--

EF

	<p>EF-0933R</p> <p>Øext.: 45 FILTRO SEC. DE CARCAZA FR-04 Øint.: 33 JOHN DEERE M123378 H.: 175 USA PRIM. EF-0932R Otros:</p>
	<p>EF-0934R</p> <p>Øext.: 105 FILTRO PRIM. DE CARCAZA FR-05 Øint.: 62 NEW HOLLAND / FIAT 1930591 H.: 302 PERKINS 901046 Otros: USA SEC. EF-0935R</p>
	<p>EF-0935R</p> <p>Øext.: 59 FILTRO SEC. DE CARCAZA FR-05 Øint.: 44 NEW HOLLAND / FIAT 1930592 H.: 286 USA PRIM. EF-0934R Otros:</p>
	<p>EF-0938R</p> <p>Øext.: 240 FILTRO PRIM. DE CARCAZA FR-12 Øint.: 123 USA SEC. EF-0939R H.: 494 Otros:</p>
	<p>EF-0939R</p> <p>Øext.: 123 FILTRO SEC. DE CARCAZA FR-12 Øint.: 108 USA PRIM. EF-0938R H.: 475 Otros:</p>
	<p>EF-0940R</p> <p>Øext.: 186 FILTRO PRIM. CARCAZA FR-09 Øint.: 106 VOLVO 91343059 / CAT 2065234 H.: 396 KOMATSU 6001852510 / 6001852500 Otros: USA SEC. EF-0941R</p>
	<p>EF-0941R</p> <p>Øext.: 108 FILTRO SEC. CARCAZA FR-09 Øint.: 87 VOLVO 91343060 / 11110284 H.: 382 CAT. 2065235 / KOMATSU 6001852520 Otros: USA PRIM. EF-0940R</p>
	<p>EF-0942R</p> <p>Øext.: 164 CNH 87682993 Øint.: 92 USA SEC. EF-0733R H.: 356 REEMP. EF-0732R Otros:</p>
	<p>EF-0943R</p> <p>Øext.: 269 IVECO CAVALLINO (EUROARGO) Øint.: 148 180E32 / 450E32 / VOLVO BUS B7R H.: 425 AGRALE-DEUTZ N° 6.112.101.056.007 Otros: M. BENZ 1218L / 14210NL / 1622L / 23 24L / 17210F N° 3760948204 USA SEC. EF-0944R</p>
	<p>EF-0944R</p> <p>Øext.: 141,5 - 147 VOLVO / IVECO 20416502 Øint.: 122 USA PRIM. EF-0943R H.: 412 Otros:</p>
	<p>EF-0945</p> <p>Øext.: 100 BOMBAS DE VACÍO Øint.: 80 REPIKY R-100 H.: 60 Otros:</p>
	<p>EF-0946</p> <p>Øext.: 150 BOMBAS DE VACÍO Øint.: 105 REPIKY R-200 / R-0.2 H.: 100 Otros:</p>
	<p>EF-0947</p> <p>Øext.: 190 BOMBAS DE VACÍO Øint.: 135 REPIKY R-0.5 / R-500 H.: 150 Otros:</p>
	<p>EF-0948</p> <p>Øext.: 210 BOMBAS DE VACÍO Øint.: 160 REPIKY R-1.0 H.: 200 Otros:</p>
	<p>EF-0949</p> <p>Øext.: 265 BOMBAS DE VACÍO Øint.: 215 REPIKY R-1.5 H.: 250 Otros:</p>
	<p>EF-0950</p> <p>Øext.: 265 BOMBAS DE VACÍO Øint.: 215 REPIKY R-2.0 / 2.5 / 3.0 H.: 350 Otros:</p>
	<p>EF-0951</p> <p>Øext.: 345 BOMBAS DE VACÍO Øint.: 295 REPIKY R-3.8 / 4.0 H.: 450 Otros:</p>
	<p>EF-0952</p> <p>Øext.: 400 BOMBAS DE VACÍO Øint.: 350 REPIKY R-4.5 / 5.0 H.: 500 Otros:</p>
	<p>EF-0953</p> <p>Largo: 495 WAUKESHA 169180F Ancho: 495 Alto: 65 Otros:</p>
	<p>EF-0954R</p> <p>Øext.: 269 CNH 87636411 Øint.: 148 AGCO 6211381M1 H.: 441 USA SEC. EF-955R Otros:</p>

	<p>EF-0955R</p> <p>Øext.: 141,5 - 147 CNH 87636412 Øint.: 122 AGCO 6211382M1 H.: 426 USA PRIM. EF-0954R Otros:</p>
---	---

	<p>EF-0965R</p> <p>Øext.: 280 KALMAR 9231100577 Øint.: 151 H.: 525 Otros:</p>
---	--

	<p>EF-0956</p> <p>Øext.: 234 - 290 IVECO 08019342 Øint.: 123 USA SEC. EF-0957 H.: 467 Otros:</p>
---	--

	<p>EF-0966R</p> <p>Øext.: 174 AGCO 6223614M1 Øint.: 106 IVECO 93829614 H.: 423 USA SEC. EF-0967R Otros:</p>
---	--

	<p>EF-0957</p> <p>Øext.: 148 IVECO 08034304 Øint.: 105 USA PRIM. EF-0956 H.: 450 Otros:</p>
---	---

	<p>EF-0967R</p> <p>Øext.: 101 AGCO 6223615 M1 Øint.: 82 USA PRIM. EF-0966R H.: 413 Otros:</p>
---	---

	<p>EF-0958</p> <p>Øext.: 245 - 215 CNH / CASE 73402784 Øint.: 123 - 11 USA SEC. EF-0726 H.: 400 Otros:</p>
---	--

	<p>EF-0968R</p> <p>Øext.: 178 KIA OK6B0 23 603 Øint.: 109 KIA 2700 CAMIÓN H.: 246 Otros:</p>
---	--

	<p>EF-0959R</p> <p>Øext.: 174 CNH 87344135 Øint.: 106 AGCO 6223618M1 H.: 352 JOHN DEERE DQ-59138 Otros: USA SEC. EF-0960R</p>
--	---

	<p>EF-0969R</p> <p>Øext.: 298 ATLAS COPCO 2914-5017-00 Øint.: 208 INGERSOLL RAND 89288971 H.: 594 Otros:</p>
--	--

	<p>EF-0960R</p> <p>Øext.: 101 CNH 87344136 Øint.: 82 AGCO 6223619M1 H.: 342 JOHN DEERE DQ-59139 Otros: USA PRIM. EF-0959R</p>
---	---

	<p>EF-0970R</p> <p>Øext.: 84 TOYOTA 17744-23600-71 Øint.: 63,5 USA PRIM. EF-0839R H.: 269 Otros:</p>
---	--

	<p>EF-0961R</p> <p>Øext.: 164 CNH 71102626 Øint.: 88 USA SEC. EF-0962R H.: 385 Otros:</p>
---	---

	<p>EF-0971</p> <p>Øext.: 275 MOTONIVELADORA PY-200G Øint.: 165 - 22 PALA CARG. MICHIGAN R95C H.: 512 (MOTOR CUMMINS) Otros: USA SEC. EF-0972</p>
---	--

	<p>EF-0962R</p> <p>Øext.: 89 CNH 71102625 Øint.: 72 USA PRIM. EF-0961R H.: 374 Otros:</p>
---	---

	<p>EF-0972</p> <p>Øext.: 162 MOTONIVELADORA PY-200G Øint.: 134 - 17 PALA CARG. MICHIGAN R95C H.: 482 (MOTOR CUMMINS) Otros: USA PRIM. EF-0971</p>
---	---

	<p>EF-0963</p> <p>Øext.: 400 - 373 FILTRO PRIM. DE CARCAZA 40 m³ Øint.: 262 - 22 CATERPILLAR 4W5228 H.: 625 USA SEC. EF-0964 Otros:</p>
---	---

	<p>EF-0973R</p> <p>Øext.: 235 PALA CARG. NEW HOLLAND W170 Øint.: 133 Nº 8501334P H.: 599 USA SEC. EF-0974R Otros:</p>
---	--

	<p>EF-0964</p> <p>Øext.: 260 FILTRO SEC. DE CARCAZA 40 m³ Øint.: 232 - 22 USA PRIM. EF-0963 H.: 572 Otros:</p>
---	---

	<p>EF-0974R</p> <p>Øext.: 133 - 126 PALA CARG. NEW HOLLAND W170 Øint.: 93 Nº 8501333P H.: 544 USA PRIM. EF-0973R Otros:</p>
---	--

EF

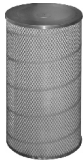

EF-0975

Øext.: 228
Øint.: 153 - 10
H.: 442
Otros:

TRACTOR PAUNY 280A
PAUNY RINO 180
USA SEC. EF-0976



EF-0976

Øext.: 151
Øint.: 123 - 17
H.: 407
Otros:

TRACTOR PAUNY 280A
PAUNY RINO 180
USA PRIM. EF-0975



EF-0977

Øext.: 218
Øint.: 124 - 12
H.: 408
Otros:

PALA CARG. LG 933
USA SEC. EF-0978 o EF-0984



EF-0978

Øext.: 116 - 140
Øint.: 87 - 12
H.: 384
Otros:

PALA CARG. LG 933
USA SEC. EF-0977



EF-0979R

Øext.: 135 - 126
Øint.: 113
H.: 352
Otros:

HITACHI 4286130
NISSAN
USA PRIM. EF-0927R



EF-0980R

Øext.: 312
Øint.: 179
H.: 582
Otros:

VOLVO 110339983
GUASCOR 76.50.287
TEREX 15272252 - N. HOLLAND
USA SEC. EF-0981R



EF-0981R

Øext.: 178 - 175
Øint.: 147
H.: 562
Otros:

VOLVO 110339991
GUASCOR 76.50.288
TEREX 15272253
USA PRIM. EF-0980R



EF-0982

Øext.: 149
Øint.: 72 - 8
H.: 236
Otros:

HANOMAG TRACTORES
250A /350A /500A HP
N° 30011A01005
USA SEC. EF-0983



EF-0983

Øext.: 79 - 65
Øint.: 57 - 17
H.: 225
Otros:

HANOMAG TRACTORES
250A /350A /500A HP
N° 30011A01006
USA SEC. EF-0982



EF-0984

Øext.: 116 - 132
Øint.: 87 - 12
H.: 380
Otros:

PALA CARG. LG
USA PRIM. EF-0977



EF-0985

Øext.: 154
Øint.: 85 - 12
H.: 330
Otros:

MICHIGAN R45C / M 1000-R45C
USA SEC. EF-0986



EF-0986

Øext.: 78 - 95
Øint.: 62 - 12
H.: 303
Otros:

MICHIGAN R45C / M 1001-R45C
USA PRIM. EF-0985



EF-0987

Øext.: 181
Øint.: 100 - 12
H.: 340
Otros:

TRACTOR HANOMAG MOD. 854
ZL 15L CKW 1833A
VARIOS / USA SEC. EF-0988



EF-0988

Øext.: 95 - 105
Øint.: 80 - 12
H.: 325
Otros:

TRACTOR HANOMAG MOD. 854
ZL15L CKW 1833A
VARIOS / USA PRIM. EF-0987



EF-0989

Øext.: 210
Øint.: 132 - 17
H.: 375
Otros:

PALA CARG. FRONTAL
TIANGONG MOD. ZL-15
USA SEC. EF-0990 o EF-1002



EF-0990

Øext.: 123
Øint.: 92 - 17
H.: 364
Otros:

PALA CARG.A FRONTAL
TIANGONG MOD. ZL-15
USA PRIM. EF-0989



EF-0991

Øext.: 302
Øint.: 200 - 9
H.: 475
Otros:

PALA CARG. LONKING LK-856
N° 10209-910323
USA SEC. EF-0992



EF-0992

Øext.: 190
Øint.: 158 - 17
H.: 447
Otros:

PALA CARG. LONKING LK-856
N° 10209-910317
USA PRIM. EF-0991



EF-0993R

Øext.: 329
Øint.: 215
H.: 308 - 362
Otros:

FILTRO DE AIRE
MOTOR MARINO
GUASCOR 76.50.038





EF-0994R

Øext.: 147 - 134
Øint.: 74 - 61
H.: 230
Otros:

NISSAN FRONTIER NP-300
N° 16546-VM00A





	<p>EF-0995R</p> <p>Øext.: 128 MINIPALA SWL 3210 Øint.: 69 USA SEC. EF-0996R H.: 309 Otros:</p>
---	--

	<p>EF-0996R</p> <p>Øext.: 94 MINIPALA SWL 3210 Øint.: 61 USA PRIM. EF-0995R H.: 295 Otros:</p>
---	--

	<p>EF-0997</p> <p>Øext.: 155 CATERPILLAR 211-2661 Øint.: 88 - 15 H.: 240 Otros:</p>
---	--

	<p>EF-0998R</p> <p>Øext.: 225 CARGADORA JOHN DEERE 444 - 644J Øint.: 182 Nº AT-300487 H.: 426 USA SEC. EF-0999R Otros:</p>
---	---

	<p>EF-0999R</p> <p>Øext.: 182 CARGADORA JOHN DEERE 444 - 644J Øint.: 93 Nº AT-314583 H.: 402 USA PRIM. EF-0998R Otros:</p>
--	---

	<p>EF-1000R</p> <p>Øext.: 312 IVECO STRALIS 380 Øint.: 216 Nº 2996126 H.: 461 Otros:</p>
---	--

	<p>EF-1001R</p> <p>Øext.: 265 GRUA TEREX DEMAG Øint.: 170 80TN - LIEBHERR H.: 480 Otros:</p>
---	--

	<p>EF-1002</p> <p>Øext.: 123 - 17 PALA CARGADORA FRONTAL Øint.: 92 LIUGONG CLG835 H.: 364 USA PRIM. EF-0989 Otros:</p>
---	---

	<p>EF-1003R</p> <p>Øext.: 265 GRUA TEREX DEMAG Øint.: 170 80TN - LIEBHERR H.: 480 Otros:</p>
---	--

FA



FA-0202

Øext.: 138 FILTRO PARA SISTEMA DE FRENO
Øint.: M 39 x 1,5 N° 432 410 0202 / 432 410 2227
H.: 165 1 487 434 001 / 1 987 434 001
Otros: 031 004 109



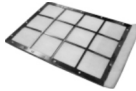

FA-2202

Øext.: 138 FILTRO PARA SISTEMA DE FRENO
Øint.: 1" 1/4x11 N° 432 410 2232 / 432 410 2262
H.: 178 432 415 2202
Otros:

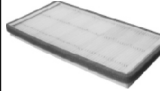
	<p>FH-2204</p> <p>Largo: 240 Ancho: 165 Alto: 5 Otros:</p> <p>PALIO / SIENA</p>
---	--

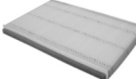
	<p>FH-2503</p> <p>Largo: 303 Ancho: 158 Alto: 30 Otros:</p> <p>GOL / SAVEIRO 377/819638</p>
---	--

	<p>FH-2205</p> <p>Largo: 258 Ancho: 190 Alto: 18 Otros:</p> <p>PALIO / SIENA 7082301</p>
---	---

	<p>FH-2551</p> <p>Largo: 330 Ancho: 175 Alto: 30 Otros:</p> <p>MERCEDES BENZ 1644 / 1844 / 1944</p>
---	--

	<p>FH-2206</p> <p>Largo: 430 Ancho: 145 Alto: 18 Otros:</p> <p>DUCATO / BOXER 5.225.206.02</p>
---	---

	<p>FH-2553</p> <p>Largo: 367 Ancho: 158 Alto: 30 Otros:</p> <p>SPRINTER TODOS A901.830.0018</p>
---	--

	<p>FH-2251</p> <p>Largo: 335 Ancho: 150 Alto: 30 Otros:</p> <p>FIESTA / KA CURRIER 1004051</p>
---	---

	<p>FH-2701</p> <p>Largo: 232 Ancho: 100 Alto: 17 Otros:</p> <p>TROOPER 3.1</p>
---	---

	<p>FH-2255K</p> <p>Largo: 510 Ancho: 109 Alto: 34 Otros:</p> <p>MONDEO 1115650</p>
---	---

	<p>FH-2702</p> <p>Largo: 225 Ancho: 167 Alto: 67 Otros:</p> <p>SCANIA</p>
---	--

	<p>FH-2304</p> <p>Largo: 345 Ancho: 200 Alto: 18 Otros:</p> <p>CORSA 1808604</p>
---	---

	<p>FH-2703</p> <p>Largo: 375 Ancho: 135 Alto: 20 Otros:</p> <p>SCANIA 2008</p>
---	---

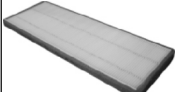
	<p>FH-2305</p> <p>Largo: 416 Ancho: 154 Alto: 15 Otros:</p> <p>VECTRA SERIE II 1808607</p>
---	---

	<p>FH-2355</p> <p>Largo: 216 Ancho: 210 Alto: 15 Otros:</p> <p>PARTNER 6447-Z5</p>
---	---

	<p>FH-2501</p> <p>Largo: 277 Ancho: 205 Alto: 26 Otros:</p> <p>BORA / GOLF III NEW BEETLE POLO 10819639</p>
---	--

	<p>FH-2502</p> <p>Øext.: 167 Øint.: 116 H.: 105 Otros:</p> <p>7D0/819989 TRANSPORTES TODOS</p>
---	---

HF



HF-3040

Øext.: 117 JOHN DEERE AR-28072 R
 Øint.: 57 AJ-54668
 H.: 140
 Otros:



HF-3041

Øext.: 100 CATERPILLAR 2M-3243
 Øint.: 58 2M-3943 / 4J-4195
 H.: 235 1R-0719
 Otros:



HF-3042

Øext.: 120 CATERPILLAR 2J-1360 / 2J-1560
 Øint.: 86 4J-806 / 1R-0778
 H.: 228
 Otros:



HF-3043

Øext.: 58 MERCEDES BENZ 0004660604
 Øint.: 18 7632141102
 H.: 100
 Otros:



HF-3044

Øext.: 92 CATERPILLAR 8B-5935
 Øint.: 35 7F-4626
 H.: 149
 Otros:



HF-3045

Øext.: 97 CLARK 234099-247050
 Øint.: 2"x16 UNF ALLIS 79104646 / CASE
 H.: 143
 Otros: válv. by-pass



HF-3046

Øext.: 152 EUCLID 9190077 / 9207229
 Øint.: 89
 H.: 216
 Otros:

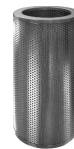

HF-3047

Øext.: 150 KOMATSU 195-60-16320
 Øint.: 110
 H.: 300
 Otros:



HF-3048

Øext.: 95 DEUTZ 3026564
 Øint.: 1"x12 UNF
 H.: 170
 Otros: válv. by-pass



HF-3048LF

Øext.: 97 SISTEMA HIDRÁULICO
 Øint.: 1"x12 UNF PAUNY-ZANELLO 0914103
 H.: 203
 Otros: válv. by-pass



HF-3049

Øext.: 150 CATERPILLAR 944412-X
 Øint.: 110 FIAT HITACHI 1384-9D-71416241
 H.: 450 HYUNDAI E1312012A
 Otros: KOMATSU 205-60-51430
 DAEWU 2474-9404A



HF-3050

Øext.: 117 JOHN DEERE 39266 / A134786
 Øint.: 58 AR-94510 / AT-78414
 H.: 205 FLUJO DE ADENTRO HACIA FUERA
 Otros:



HF-3051

Øext.: 97 ZANELLO 515920 - 0914103
 Øint.: 1"x12 UNF
 H.: 202
 Otros: válv. anti retorno/válv. by-pass



HF-3052

Øext.: 110 ZANELLO 342625 - 0902004
 Øint.: 1" 1/8x16
 H.: 262
 Otros: válv. by-pass



HF-3053

Øext.: 85 FIAT 1909106 / 1909127 / 4998327
 Øint.: 41 NEW HOLLAND 1909106
 H.: 207
 Otros: válv. by-pass



HF-3054

Øext.: 130 CATERPILLAR 4T-0522
 Øint.: 85
 H.: 177
 Otros:



HF-3055

Øext.: 73 VALMET 880-980
 Øint.: 32 N° 433800
 H.: 89 - 95
 Otros:



HF-3056

Øext.: 83 VALMET 30250100
 Øint.: 10,5 - 44 (METÁLICO)
 H.: 116 - 122
 Otros:



HF-3057

Øext.: 73 VALMET 138-1380-68-78-88-685
 Øint.: 11 - 33 N° 242510
 H.: 107 - 112
 Otros:



HF-3058

Øext.: 64 DEUTZ 4009469
 Øint.: 3/4"x14 BSP UCSE N 1320
 H.: 109
 Otros:



HF-3059
 Øext.: 95 VALMET 30606000
 Øint.: M 24x1,5 ALTA PRESIÓN
 H.: 165
 Otros: válv. anti retorno/válv. by-pass



HF-3060
 Øext.: 78 MASSEY FERGUSON 9005281M
 Øint.: 3/4"x16
 H.: 139
 Otros: válv. by-pass



HF-3061
 Øext.: 97 FORD TRACTORES
 Øint.: 1 1/8"x16 D8NNB 486 DA
 H.: 180
 Otros: válv. by-pass



HF-3062
 Øext.: 112 SAME 244192800
 Øint.: M 40x2 NEW HOLLAND 1930910-1
 H.: 232
 Otros:



HF-3063
 Øext.: 97 M. FERGUSON 9007871 M1
 Øint.: 3/4"x14 BSP 9010178 M1
 H.: 143 SIST. HIDRÁULICO UCC 2408
 Otros: válv. anti retorno/válv. by-pass



HF-3064
 Øext.: 85 M. FERGUSON (HIDRÁULICO)
 Øint.: 8,5 - 31 1486474-M91
 H.: 75 WABCO KC-6086
 Otros:



HF-3065
 Øext.: 93,5 IHC 261906-R91
 Øint.: 48,5 GM 6438408
 H.: 188,8
 Otros:

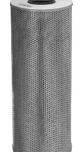

HF-3066
 Øext.: 152 CLARK 233333
 Øint.: 54
 H.: 436
 Otros:



HF-3067
 Øext.: 85 LINDE H25 - Nº 0009830601
 Øint.: 3/4"x16 UNF HYSTER 297865 alta presión
 H.: 148
 Otros: válv. by-pass



HF-3068
 Øext.: 97 CLARK 247052
 Øint.: 2"x16 UNF 2366807
 H.: 180
 Otros: válv. by-pass



HF-3069
 Øext.: 92 HIDRÁULICO DE RETORNO
 Øint.: 3/4"x16 UNF VASSALLI PLATAFORM
 H.: 140
 Otros: válv. by-pass



HF-3070
 Øext.: 92 VALTRA SISU 80634900
 Øint.: M 24x1,5
 H.: 213
 Otros: válv. anti retorno/válv. by-pass



HF-3071
 Øext.: 127 CATERPILLAR 9J-5461
 Øint.: 84,5 - 19 9J-750 / 1R-0722 / 1R-0774
 H.: 280 GM 25010964
 Otros:



HF-3072
 Øext.: 114 FIAT ALLIS 70679512 / 70679513
 Øint.: 56,5 CATERPILLAR 3I-1323 / AT-45810
 H.: 179
 Otros:



HF-3073
 Øext.: 100 KOMATSU 175-49-11580
 Øint.: 41 611-4505/100
 H.: 234 CAT. 1R 0659
 Otros:



HF-3074
 Øext.: 103,5 KOMATSU 175-60-27380
 Øint.: 85,6
 H.: 294
 Otros:



HF-3075
 Øext.: 129 FILTRO CAPTOR PRIMERA FASE
 Øint.: 96,8 AISI 304SS - 60 MICRONES
 H.: 458
 Otros:



HF-3076
 Øext.: 129 FILTRO CAPTOR SEGUNDA FASE
 Øint.: 96,8 (10 MICRONES) - PAPEL
 H.: 458
 Otros:







HF-3077
 Øext.: 129 FILTRO CAPTOR SEGUNDA FASE
 Øint.: 96,8 5 MICRONES - PAPEL
 H.: 458
 Otros:



HF-3078
 Øext.: 97 TADANO 36670040010
 Øint.: 1 1/8"x16 CATERPILLAR 0937521
 H.: 180
 Otros:

HF

	HF-3079 Øext.: 52,4 Øint.: 32 H.: 173 - 178 Otros:	PUROLATOR 852127 / 7500501
	HF-3081 Øext.: 67 Øint.: 32,5 H.: 121 - 116 Otros:	N° ORIGINAL 6292067120
	HF-3083 Øext.: 55 Øint.: 27 H.: 68 - 64 Otros:	ARGO V30607-08 DEUTZ S-170 DEUTZ 16006845
	HF-3085 Øext.: 95 Øint.: 1"x12 H.: 140 Otros:	GRESIN 1551 - 1553 LENZ CP752-10
	HF-3087 Øext.: 97 Øint.: 1 3/8"x12 H.: 154 Otros:	CLARK 6599543
	HF-3089 Øext.: 97 Øint.: 1 3/8"x12 H.: 154 Otros:	CLARK 6630977 MELROE BOBCAT 6661248
	HF-3091 Øext.: 97 Øint.: 7/8"x14 H.: 154 Otros: válv. by-pass	CLARK 2782050 - 2791199 244195 - 2816961 - 2792962
	HF-3093 Øext.: 101 Øint.: 27 H.: 35 Otros:	FORD - NEW HOLLAND 9577743 DIRECCIÓN HIDRÁULICA
	HF-3095 Øext.: 92 Øint.: 3/4"x16 H.: 140 Otros: válv. anti retorno/válv. by-pass	CLARK 990937 - 1777935 HID. PRESIÓN
	HF-3097 Øext.: 97 Øint.: 1 1/8"x16 H.: 140 Otros: válv. by-pass	CASE 9010-9030 N° 150794A1
	HF-3080 Øext.: 100 Øint.: 58 H.: 234 Otros:	CATERPILLAR 9M9740 CAT.-1R-0719
	HF-3082 Øext.: 83,5 Øint.: 50,5 H.: 227 Otros:	TROMPO-HORMIGONERO ESTERER (SF251P10-MP FILTER)
	HF-3084 Øext.: 142 Øint.: 98 H.: 415 - 425 Otros:	CAT. 320BL / 1262081 (FILTRO HID. DE SUCCIÓN DE TANQUE)
	HF-3086 Øext.: 97 Øint.: 1 3/8"x12 H.: 242 Otros:	CLARK 6598903
	HF-3088 Øext.: 51 Øint.: 22 H.: 203 Otros:	CLARK 920007 FAIREY ARLOX PXW2A/CC10
	HF-3090 Øext.: 97 Øint.: 1 3/8"x12 H.: 242 Otros:	CATERPILLAR 1G-8878 JOHN DEERE RE39527 CNH 81863799
	HF-3092 Øext.: 97 Øint.: 13/16"x16 H.: 154 Otros: válv. by-pass	CASE 254686 A1 - 181167 A1 KOMATSU CA-0139413
	HF-3094 Øext.: 80 Øint.: 3/4"x16 H.: 144 Otros: válv. by-pass	LINDE 0009830623 0009830618 HAMM 00268046 CASE 45144600
	HF-3096 Øext.: 100 Øint.: 58 H.: 210 Otros:	KOMATSU 154-60-12170 14X4932750
	HF-3098 Øext.: 97 Øint.: 1 3/8"x12 H.: 154 Otros:	J. DEERE AL-77061 JBC 32/905501 TRACT. SERIE 6000



HF-3099
 Øext.: 123 SISTEMAS HIDRÁULICOS
 Øint.: 1 1/4"x11 BSP B10 = 75
 H.: 285
 Otros:



HF-3100
 Øext.: 123 SISTEMAS HIDRÁULICOS
 Øint.: 1 1/4"x11 BSP B25 = 50
 H.: 285 SULLAIR 250025-526.
 Otros:



HF-3101
 Øext.: 130 UCC-UC-2418 HY SISTEMAS
 Øint.: 1 1/4"x11 BSP NEW HOLLAND 89814477
 H.: 176 AGCO 9010163M1
 Otros: válv. anti retorno/válv. by-pass



HF-3102
 Øext.: 60 M. FERGUSON 9002971 M91
 Øint.: 39 - 9,5
 H.: 62
 Otros:



HF-3103
 Øext.: 60 M. FERGUSON 1870199 M92
 Øint.: 39 - 9,5
 H.: 92
 Otros:



HF-3104
 Øext.: 97 CATERPILLAR 3T-8642
 Øint.: 1 1/2"x16 Un2 J. DEERE AT-63557
 H.: 203
 Otros:



HF-3105
 Øext.: 87 MICHIGAN 230962 - B54=75
 Øint.: 28 ALLIS CHALMERS 10049229
 H.: 143 CASE D52932
 Otros: M. FERGUSON 1088695-M91

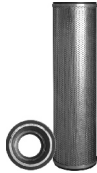

HF-3106
 Øext.: 129 FILTRO CAPTOR 30 MICRONES
 Øint.: 96,8 PAPEL
 H.: 458
 Otros:



HF-3107
 Øext.: 129 FILTRO CAPTOR
 Øint.: 96,8 MALLA INOX
 H.: 458 120 MICRONES
 Otros:



HF-3108
 Øext.: 63 AGCO / DEUTZ 04009348
 Øint.: 42 - 10,5
 H.: 137,5
 Otros:



HF-3109
 Øext.: 96 USA CABEZAL DH-1500
 Øint.: 50,5 MALLA INOX
 H.: 198 SULLAIR 001158
 Otros:



HF-3110
 Øext.: 97 CASE D94236 - N9025 - N14232
 Øint.: 1 3/8"x12 CATERPILLAR 9T-5916
 H.: 240
 Otros:



HF-3111
 Øext.: 123 UCC - MX 1591810
 Øint.: 1 1/4"x11 BSP
 H.: 220
 Otros:



HF-3112
 Øext.: 97 ZF-0750-151-012/032/056
 Øint.: M 24x1,5 J. DEERE AT-179323
 H.: 168 ZANELLO 713015/W-121
 Otros: DYNAPAC 499575 / CRYBSA 0440579



HF-3113
 Øext.: 97 ZF 0750 131 013/60
 Øint.: M 24x1,5 ZF 050 121 0683 / 0750 131 053
 H.: 223 J. DEERE AT-168989
 Otros: AT-102377 / AT -140030
 DEUTZ 4305722



HF-3114
 Øext.: 43 31 E3-0018
 Øint.: 22,5 PALA CARGADORA HYUNDAI
 H.: 88 HL-707-7
 Otros: DOOSAN 2471-1154



HF-3115
 Øext.: 96 FILTRO CABEZAL DH-1500
 Øint.: 50,5 15 MICRONES
 H.: 198
 Otros:



HF-3116
 Øext.: 97 DAEWOO D141099
 Øint.: 1"x12 INTERNACIONAL 70203-C1
 H.: 140 CASE A32297
 Otros:























HF-3117
 Øext.: 97 NEW HOLLAND 86989733
 Øint.: 1 3/8"x12
 H.: 232
 Otros:



HF-3118
 Øext.: 123 UCC - MX 1591-4-10 RGEF
 Øint.: 1 1/4"x11 BSP
 H.: 176
 Otros:

HF

	HF-3119 Øext.: 129 EQUIPO CAPTOR Øint.: 96,8 MALLA FILTRANTE H.: 458 INOX. 30 micr. Otros:
	HF-3120 Øext.: 97 ALTA PRESIÓN - VOLVO 4787923-4 Øint.: 1"x12 LIEBHERR ZF-0750131007 H.: 210 TRANSMISIÓN HIDROSTÁTICA Otros: válv. by-pass MF 2979653M1/BOMAG 05821212
	HF-3121 Øext.: 83 FILTRO COSECHADORA Øint.: 27,5 LAVERDA H.: 136 - 141 Otros:
	HF-3122 Øext.: 150 PALA CARGADORA HYUNDAI Øint.: 84 ORIGINAL Nº 34L3-00341-A H.: 156 RETORNO Otros:
	HF-3123 Øext.: 150 PALA CARGADORA HYUNDAI Øint.: 84 HYUNDAI E131-0212 H.: 205 Otros:
	HF-3124 Øext.: 150 PALA CARGADORA Øint.: 84 HYUNDAI E131-0212 H.: 456 Otros:
	HF-3125 Øext.: 123 UCC - MX 1591-4-25 Øint.: 1 1/4"x11 BSP B25=50 H.: 176 Otros:
	HF-3126 Øext.: 97 NEW HOLLAND 898 11117 Øint.: 3/4"x14 BSP H.: 140 Otros:
	HF-3127 Øext.: 100 FILTRO HIDRÁULICO REEMPLAZA Øint.: 42 MP FILTRI MF1801AP10NB H.: 210 RE 50CD1 Otros:
	HF-3128 Øext.: 123 SISTEMA HIDRÁULICO Øint.: 1 1/4"x11 BSP 120 MICRONES H.: 285 (TRANSMISIÓN). Otros:
	HF-3129 Øext.: 97 JOHN DEERE AT-222005 Øint.: M 24x1,5 ZF 0750131061 H.: 223 DAEWOO 474-00021 Otros:
	HF-3130 Øext.: 96 FILTRO CABEZAL Øint.: 50,5 DH-1500 H.: 198 30 MICRONES Otros:
	HF-3131 Øext.: 129 EQUIPO CAPTOR Øint.: 96,8 MALLA FILTRANTE H.: 458 INOX. 80 MICRONES. Otros:
	HF-3132 Øext.: 102 CNH 87661828 Øint.: 42 ELEMENTO MALLA H.: 221 INOX. 100 MICRONES. Otros: OPCIONAL HF-3136
	HF-3133 Øext.: 134 SISTEMA HIDRÁULICO Øint.: 1 1/2"x16 SANDVIK 912.0126.00 HC-69 H.: 305 Otros:
	HF-3134 Øext.: 97 SISTEMA HIDRÁULICO Øint.: 1"x12 SANDVIK 912.0129.00 H.: 203 HC-2/DYNAPAC 499519 Otros: (10 MICRONES)
	HF-3135 Øext.: 97 STAUFF SF-6521 Øint.: 1"x12 HYDAC 610087/LHA-SPE H.: 203 INGERSOL RAND 59026506 Otros: CNH / METALFOR (10 MICRONES)
	HF-3136 Øext.: 102 CNH 73401383 Øint.: 42 MEDIO FILTRANTE PAPEL H.: 224 OPCIONAL HF-3132. Otros:
	HF-3137 Øext.: 129 FILTRO CAPTOR SEGUNDA FASE Øint.: 96,8 2 MICRONES (ALTA EFICIENCIA) H.: 458 Otros:
	HF-3138 Øext.: 100 FILTRO HIDRÁULICO Øint.: 42 KOMATSU 281-16-11290 H.: 232 Otros:



HF-3139

Øext.: 140 AGCO 1484054M2 / M.FERGURSON
 Øint.: 80 HANOMAG 86HS (RETROEXCAVADORA)
 H.: 228 MWM A4 -4.1 (2002) / M. FERGURSON
 Otros: TRACT. 750 - PERKINS 4.236 (1994)



HF-3140

Øext.: 97 LINDE 000.983.06.15
 Øint.: 1"x12 (ALTA PRESIÓN)
 H.: 174
 Otros: válv. by-pass



HF-3141

Øext.: 110 SISTEMA HIDRÁULICO
 Øint.: 1"x12 VENTURI 95032546
 H.: 234 METALFOR 205400331 - (25 MICRONES)
 Otros: válv. anti retorno/válv. by-pass



HF-3142

Øext.: 128 AGCO 034391T1
 Øint.: 1 1/2"x16 UNF
 H.: 242
 Otros:



HF-3143

Øext.: 128 AGCO 042285R1
 Øint.: 1 1/2"x16 UNF
 H.: 176
 Otros:



HF-3144

Øext.: 130 SISTEMA HIDRÁULICOS
 Øint.: 1 1/4"x11 BSP 25 MICRONES
 H.: 176 SOFIMA CA-301ECV1
 Otros:



HF-3145

Øext.: 100 PALA CARGADORA CHINA
 Øint.: 47 THW140
 H.: 124
 Otros:



HF-3146

Øext.: 130 FUMIGADORA PLA
 Øint.: 1 1/4"x11 BSP MALLA METÁLICA
 H.: 233 125 MICRONES
 Otros: (SOE 15/125)



HF-3150

Øext.: 38 TRANSMISION CARRARO
 Øint.: 23 N° 135859
 H.: 83 (TLV1 UP 4WD REF. CA 359169)
 Otros:



HF-3912

Øext.: 136 AGCO N° 04803938
 Øint.: M 45x1,5
 H.: 307
 Otros:

FILTROS PARA COMBUSTIBLE

Cartuchos

PF

	<p>PF-2000/12</p> <p>Øext.: 46 RACOR 2000 SM 12 MICRONES Øint.: 12 H.: 74 Otros:</p>
	<p>PF-2000/30</p> <p>Øext.: 46 RACOR 2000 SM 30 MICRONES Øint.: 12 H.: 74 Otros:</p>
	<p>PF-2010/12</p> <p>Øext.: 86 12 MICRONES - DAHL 505 Øint.: 16 RACOR 2010 SERIE 500 H.: 69 Otros:</p>
	<p>PF-2010/30</p> <p>Øext.: 86 30 MICRONES - DAHL 505 Øint.: 16 RACOR 2010 SERIE 500 H.: 69 Otros:</p>
	<p>PF-2020N/2</p> <p>Øext.: 111 FILTRADO FINAL Øint.: 13 - 21 2 MICRONES H.: 244 Otros:</p>
	<p>PF-2020N/4</p> <p>Øext.: 111 4 MICRONES (TAPA MARRON) Øint.: 13 - 21 FILTRADO FINAL/SEC. H.: 244 SCANIA 1671502 Otros:</p>
	<p>PF-2020N/12</p> <p>Øext.: 111 12 MICRONES - FILTRADO INICIAL / SEC. Øint.: 13 - 21 RACOR 2020 - SCANIA 1671502 H.: 244 VOLVO 3340064 / DEUTZ 4021036 Otros: AGCO 04804247 / 04804248</p>
	<p>PF-2020N/30</p> <p>Øext.: 111 30 MICRONES / FILTRADO INICIAL Øint.: 13 - 21 SE REQUIERE FILTRO SEC. ó FINAL H.: 244 SCANIA 1671502 Otros:</p>
	<p>PF-2040N/2</p> <p>Øext.: 111 FILTRADO FINAL Øint.: 16 - 21 2 MICRONES H.: 118 Otros:</p>
	<p>PF-2040N/4</p> <p>Øext.: 111 4 MICRONES Øint.: 16 - 21 FILTRADO FINAL ó SEC. H.: 118 SCANIA 1675795 Otros:</p>
	<p>PF-2040N/12</p> <p>Øext.: 111 12 MICRONES - FILTRADO INICIAL ó SEC. Øint.: 16 - 21 RACOR 2040 - SCANIA 1675795 H.: 118 VOLVO 8125469 Otros: AGCO 4400544 / DEUTZ 4021035</p>
	<p>PF-2040N/30</p> <p>Øext.: 111 30 MICRONES - FILTRADO INICIAL, Øint.: 16 - 21 SE REQUIERE FILTRO H.: 118 SEC. ó FINAL - SCANIA 1675795 Otros:</p>
	<p>PF-550</p> <p>Øext.: 76 GM 5574558 Øint.: 27 JOHN DEERE AJ50637 H.: 197 Otros:</p>
	<p>PF-552</p> <p>Øext.: 64 BOSCH 1/2 LITRO Øint.: 14 H.: 111 Otros:</p>
	<p>PF-553</p> <p>Øext.: 79 BOSCH 1 LITRO Øint.: 14 H.: 142 Otros:</p>
	<p>PF-554</p> <p>Øext.: 76 GM 5182041 Øint.: 26 CASE PRIMARIO FUEL H.: 146 FIAT ALLIS Otros:</p>
	<p>PF-555</p> <p>Øext.: 76 GM 5573712 - 5575296 Øint.: 26 CASE A7627 SEC. FUEL H.: 104 Otros:</p>
	<p>PF-556</p> <p>Øext.: 82 DAEWOO CAMION Øint.: 14 H.: 143 Otros:</p>
	<p>PF-557</p> <p>Øext.: 64 BOSCH 1/2 LITRO (PAÑO) Øint.: 14 H.: 111 Otros:</p>
	<p>PF-558</p> <p>Øext.: 92,5 FIAT CAMIONES Y TRAC. 600/55.55L Øint.: 25 R60/780R/ 70757242 H.: 188 Otros:</p>



PF-559
 Øext.: 80 - 65 PEUGEOT 405, 306, 205
 Øint.: 19 DIESEL, MEGANE T.
 H.: 58
 Otros:



PF-560 SC
 Øext.: 134 APLICACIÓN SEP. DE AGUA
 Øint.: 33 - 67 LCS-2000 (15 MICRONES)
 H.: 354
 Otros:



PF-560/1 SC
 Øext.: 134 APLICACIÓN SEP. DE AGUA
 Øint.: 33 - 67 LCS-2001 (15 MICRONES)
 H.: 354
 Otros:



PF-560/2 SC
 Øext.: 134 APLICACIÓN SEP. DE AGUA
 Øint.: 33 - 67 LCS-2001 (5 MICRONES)
 H.: 354
 Otros:



PF-561
 Øext.: 79 BOSCH 1 LITRO
 Øint.: 14
 H.: 138
 Otros:



PF-562
 Øext.: 73 PERKINS 32543
 Øint.: 21
 H.: 85
 Otros:



PF-563
 Øext.: 70 CLIO DIESEL
 Øint.: 19 MEGANE DIESEL
 H.: 51
 Otros:



PF-564
 Øext.: 103 CATERPILLAR
 Øint.: 44 8N-9850, 1R-071
 H.: 236
 Otros:



PF-565
 Øext.: 82 - 71 RENAULT EXPRESS
 Øint.: 19 CLIO DIESEL C/VA
 H.: 85
 Otros:



PF-566
 Øext.: 82 - 71 PEUGEOT 405, 306, 205 DIESEL
 Øint.: 19
 H.: 63
 Otros:



PF-567
 Øext.: 76 FILTRO PARA SURTIDOR
 Øint.: 30 (PR 172)
 H.: 241
 Otros:



PF-568
 Øext.: 78 - 66 RENAULT KANGOO 1.9 DIESEL
 Øint.: 19 N° 7701206119
 H.: 77
 Otros:



PF-569
 Øext.: 96 - 70 PEUGEOT 206 DIESEL N° 190648
 Øint.: 19 PARTNER - CITROËN XSARA 190649
 H.: 73 - 80
 Otros:



PF-571
 Øext.: 94 FIAT 1909107
 Øint.: 13,5 - 27 GM 25013207 (FC-774)
 H.: 186
 Otros:



PF-572
 Øext.: 87 JOHN DEERE
 Øint.: 19 AR28610R / AR28611R
 H.: 106
 Otros:



PF-573
 Øext.: 99 A-293/1 ROPACO-1
 Øint.: 16,5
 H.: 165 - 170
 Otros:



PF-574
 Øext.: 120 A-293/2 ROPACO-2
 Øint.: 20
 H.: 192 - 198
 Otros:



PF-575
 Øext.: 145 A-293/3 ROPACO-3
 Øint.: 25
 H.: 216 - 223
 Otros:



PF-576
 Øext.: 104 BOMBA DE TRANSBASE DE
 Øint.: 19 - 44 COMBUSTIBLE MTA-450
 H.: 123
 Otros:



PF-577
 Øext.: 100 TADANO GRÚA
 Øint.: 28
 H.: 138
 Otros:

PF



PF-578

Øext.: 126
 Øint.: 26
 H.: 217
 Otros: TADANO GRÚA



PF-579

Øext.: 82
 Øint.: 30
 H.: 76
 Otros: PEUGEOT 406
 1.9 / 2.0 HDI



PF-580

Øext.: 63 - 69,5
 Øint.: 45,5
 H.: 285
 Otros: FILTRO DE GAS MOTOR



PF-581

Øext.: 149
 Øint.: 31 - 31
 H.: 366
 Otros: ELECTROEROSIONADORA
 H15190-16



PF-582

Øext.: 125,5
 Øint.: 25 - 25
 H.: 303
 Otros: ELECTROEROSIONADORA

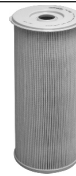

PF-583

Øext.: 134
 Øint.: 33 - 33
 H.: 330
 Otros: FILTRO DE 2DA. ETAPA DE
 LCS-2000/LCS-2001 (4 MIC).



PF-584

Øext.: 70
 Øint.: 19 - 9
 H.: 96
 Otros: GM 90542912
 ASTRA-CORSA-VECTRA



PF-585

Øext.: 36
 Øint.: 15
 H.: 90
 Otros: YANMAR NS 5055701





PF-586

Øext.: 37
 Øint.: 14
 H.: 48
 Otros: FILTRO CELULOSA
 CABEZAL CB-5129.

	<p>PN-132</p> <p>Øext.: 110 Øint.: 38 H.: 232 Otros:</p>	<p>ALLIS CH. 4371021 GM 5573014</p>
---	---	---

	<p>PN-133</p> <p>Øext.: 130 Øint.: 85 H.: 228 Otros:</p>	<p>CATERPILLAR 6H-9999 / 1R-0721 LE ROI 43-277</p>
---	---	--

	<p>PN-151</p> <p>Øext.: 109 Øint.: 37 H.: 230 Otros:</p>	<p>VOLVO 6617506-8 GM - CLARK 5576711 FIAT 6407803 JOHN DEERE AH61470</p>
---	---	---

	<p>PN-160</p> <p>Øext.: 100 Øint.: 14 H.: 203 Otros:</p>	<p>MERCEDES BENZ 911 - 1112 - 1114</p>
---	---	--

	<p>PN-161</p> <p>Øext.: 105 Øint.: 14 H.: 242 Otros:</p>	<p>MERCEDES BENZ 1519 - 1521 - 1526</p>
---	---	---

	<p>PN-162</p> <p>Øext.: 100 Øint.: 14 H.: 129 Otros:</p>	<p>MERCEDES BENZ L 608 - LO 608 JOHN DEERE AJ-1142</p>
---	---	--

	<p>PN-163</p> <p>Øext.: 121 Øint.: 43 H.: 228 Otros:</p>	<p>MERCEDES BENZ 1517 - 1518 FIAT 822434</p>
---	---	--

	<p>PN-164</p> <p>Øext.: 120 Øint.: 56 - 14 H.: 166 Otros:</p>	<p>MERCEDES BENZ 1633</p>
---	--	---------------------------

	<p>PN-165</p> <p>Øext.: 84 Øint.: 23,5 H.: 134 Otros:</p>	<p>MERCEDES BENZ L 710 OM 364</p>
--	--	---------------------------------------

	<p>PN-166</p> <p>Øext.: 120 Øint.: 56 - 14 H.: 243 Otros:</p>	<p>MERCEDES BENZ 1935 - 1938 MOTOR MANN MODELO 9L20/27</p>
--	--	--

	<p>PN-167</p> <p>Øext.: 84 Øint.: 23,5 H.: 196 Otros:</p>	<p>MERCEDES BENZ L 1215 OH 1315 L 1619 OH 1319</p>
---	--	--

	<p>PN-168</p> <p>Øext.: 97 Øint.: 34,5 H.: 118 Otros:</p>	<p>PERKINS 7106 32599 - 5031031</p>
---	--	---

	<p>PN-169</p> <p>Øext.: 165 Øint.: 60 H.: 480 Otros:</p>	<p>ELEMENTO ACEITE</p>
---	---	------------------------

	<p>PN-170</p> <p>Øext.: 121 Øint.: 43 H.: 152 Otros:</p>	<p>MERCEDES BENZ 608 (AÑO 86 EN ADELANTE)</p>
---	---	---

	<p>PN-171</p> <p>Øext.: 110 Øint.: 56 H.: 228 Otros:</p>	<p>DAEWOO CAMIÓN</p>
---	---	----------------------

	<p>PN-172</p> <p>Øext.: 93 Øint.: 34 H.: 196 Otros:</p>	<p>FIAT 700/780/180R 650/450/660/780R</p>
---	--	---

	<p>PN-173</p> <p>Øext.: 103 Øint.: 41 H.: 235 Otros:</p>	<p>CATERPILLAR 7M-3800 MERCEDS BENZ</p>
---	---	---

	<p>PN-174</p> <p>Øext.: 90 Øint.: 25 - 11 H.: 195 Otros:</p>	<p>MERCEDES BENZ 180 D 617-184-01-25 PICK UP - FURGÓN</p>
---	---	---

	<p>PN-175</p> <p>Øext.: 73 Øint.: 36 H.: 229 Otros:</p>	<p>CATERPILLAR 1S-9159 9F-6742 - LE ROI</p>
---	--	---

	<p>PN-176</p> <p>Øext.: 80 Øint.: 48 H.: 229 Otros:</p>	<p>CATERPILLAR 4J-0816</p>
---	--	----------------------------

FILTROS PARA ACEITE

Cartuchos

PN



PN-177

Øext.: 90
Øint.: 25 - 11
H.: 168
Otros:

MERCEDES BENZ 601 184 0025
616 180 0510
SSANGYONG - MUSSO



PN-179

Øext.: 194
Øint.: 117
H.: 183
Otros:

GRÚA OMEGA PYH
DEUTZ 1172637



PN-180/5

Øext.: 195
Øint.: 22
H.: 383
Otros:

FILTRO DE ACEITE
DERIVADOR
5 MICRONES



PN-180/10

Øext.: 195
Øint.: 22
H.: 383
Otros:

FILTRO DERIVADOR ESPECIAL
10 MICRONES



PN-180/20

Øext.: 195
Øint.: 22
H.: 383
Otros:

FILTRO DE ACEITE
DERIVADOR
REMP. 3845-LF-750 C-750



PN-181

Øext.: 127
Øint.: 38
H.: 244 - 250
Otros:

CUMMINS 158139



PN-182

Øext.: 114
Øint.: 45,5
H.: 224 - 228
Otros:

IHC 346609-R91 / MWM
KOMATSU 42416-11140
CASE D83130 /268462R91



PN-183

Øext.: 113
Øint.: 38
H.: 149
Otros:

GM 5574978



PN-184

Øext.: 114
Øint.: 45,5
H.: 180
Otros:

CASE - JOHN DEERE
GRESEN 1509 - 1567LP - 509



PN-184/10

Øext.: 114
Øint.: 45,5
H.: 180
Otros:

CASE - JOHN DEERE
GRESEN 1509 - 1567LP - 509



PN-185

Øext.: 160
Øint.: 22,5
H.: 382
Otros:

KOMATSU 6128-51-5030



PN-186

Øext.: 170
Øint.: 97
H.: 755
Otros:

VENTEO CARTER
MOTOR CUMMINS



PN-187

Øext.: 192
Øint.: 118
H.: 179
Otros:

MOTOR MAN ECHEVERRIA
MARINO DEUTZ 1172637



PN-188

Øext.: 100
Øint.: 45
H.: 229
Otros:

CARGADORA KOMATSU WA-70-1
N° 4241611140





PN-189

Øext.: 112
Øint.: 62
H.: 409
Otros:

CARGADORA CLACK 35C

	<p>RA-7001</p> <p>Øext.: 82,5 MERCEDES BENZ 606 180 0009 Øint.: 36 - 36 606 184 0025 VIANO 2.3 D H.: 169 MERCEDES BENZ 606 184 0125 Otros: 606 184 0225 VIANO 2.3 TD</p>
---	--

	<p>RA-7002</p> <p>Øext.: 83 FORD 1025629, 95 VW6714AB Øint.: 21 - 37 VW GOL GTI 2,8 i VRG - GOLF H.: 109,2 V.A.G. 021 115 561 B, 021 115 562AB Otros: AUDI A8 4,2 V 8 / JEEP CHEROKEE > 00</p>
---	---

	<p>RA-7003</p> <p>Øext.: 64 FORD 1100696, XM216744AA Øint.: 25 AUDI A3 TD 1,9 i - WW POLO - GOLF H.: 154 PASSAT - SEAT CORDOBA-TOLEDO 1,9 TDI Otros: V.A.G. 038 115 466, 074 115 562 VW 074115562 BORA 1,9 TDI</p>
---	--

	<p>RA-7005</p> <p>Øext.: 62 MERCEDES BENZ Øint.: 21 - 22 104 180 0109 - 104 184 0225 H.: 159 104 184 0325 - 104 184 0425 Otros: 104 184 0825 - 00A 115 466</p>
---	--

	<p>RA-7006</p> <p>Øext.: 52 MERCEDES BENZ 166 180 0009 Øint.: 22 166 180 0109 - CLASE A160 H.: 78 166 180 0710 - 166 184 0525 Otros: CLASE A 160 1,61 8 V</p>
---	---

	<p>RA-7007</p> <p>Øext.: 63,5 MERCEDES BENZ 001 184 9425 Øint.: 31 611 180 0009 C220 CDI - TD H.: 115 112 180 0009 - 112 184 0025 OM-611 Otros: SPRINTER 311 - 313 - 413 E270 OM-611 - LAREDO 2,7</p>
---	---

	<p>RA-7009</p> <p>Øext.: 80 - 82 AGCO DEUTZ TRACTOR 6.125 Øint.: 27,9 - 39 Nº 0293-1093 H.: 214 MERCEDES BENZ 906-1800009 Otros: RENAULT 50018469993</p>
---	--

	<p>RA-7012</p> <p>Øext.: 64 GM 90570368 - 90544191 Øint.: 31 - 31 9117321 - 90540460 H.: 116 OPEL 5650319 - SAAB4772166 Otros: VECTRA - ASTRA TD - ZAFIRA</p>
---	---

	<p>RA-7013</p> <p>Øext.: 62 GM 90536362 - 9192426 Øint.: 25 - 30 5650316 - 650308 - OPEL H.: 72 - 78 GM 21018826 Otros: CORSA NAFTERO 1,8 651</p>
---	---

	<p>RA-7015</p> <p>Øext.: 71,5 GM 97223218 - ISUZU 897223170 Øint.: 31 OPEL 650300 - MERIVA H.: 92 HONDA 15430-PLZ-D00 Otros: CORSA GL / GLX 1,7 CDTI - CORSA II D</p>
---	---

	<p>RA-7016</p> <p>Øext.: 82,5 BMW 11427512301 - 11427512300 Øint.: 42 11427509,430 - 11421740 534 H.: 104 11421427908 - 7509430 Otros: BMW 328 i, 328 i CABRIO 23 COUPE 525 i -523 i</p>
---	--

	<p>RA-7017</p> <p>Øext.: 82,5 BMW 11 42 2 246 131 Øint.: 36 - 36 11 42 2 246 135 525 H.: 159,5 GM 90542604 - 5650307 - 5650308 Otros: LAND ROVER STC 3350</p>
---	---

	<p>RA-7018</p> <p>Øext.: 63,5 CASE - JOHN DEERE Øint.: 31 - 31 GRESEN 1509 - 1567LP - 509 H.: 115 Otros:</p>
---	--

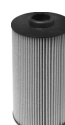
	<p>RA-7019</p> <p>Øext.: 83 CASE - JOHN DEERE Øint.: 25 - 35 GRESEN 1509 - 1567LP - 509 H.: 161 - 151 Otros:</p>
---	--

	<p>RA-7021</p> <p>Øext.: 73 KOMATSU 6128-51-5030 Øint.: 24 - 24 H.: 79 Otros:</p>
---	--

	<p>RA-7022</p> <p>Øext.: 73 VENTEO CARTER Øint.: 32 - 35 MOTOR CUMMINS H.: 197 Otros:</p>
---	---

	<p>RA-7023</p> <p>Øext.: 70,5 MOTOR MAN ECHEVERRIA Øint.: 15,2 - 33,3 MARINO DEUTZ 1172637 H.: 140,5 Otros:</p>
---	---

	<p>RA-7025</p> <p>Øext.: 83 CARGADORA KOMATSU WA-70-1 Øint.: 28 - 37 - 9,5 Nº 4241611140 H.: 149,5 Otros:</p>
---	---

	<p>RA-7026</p> <p>Øext.: 83 - 83 CARGADORA CLACK 35C Øint.: 28 - 39 - 9 H.: 199 - 210 Otros:</p>
---	---

	<p>RA-7028</p> <p>Øext.: 76 CARGADORA CLACK 35C Øint.: 28 - 28 H.: 79 Otros:</p>
---	---

RA

	<p>RA-7030</p> <p>Øext.: 70 MERCEDES BENZ 606 180 0009 Øint.: 29,5 606 184 0025 VIANO 2.3 D H.: 72 MERCEDES BENZ 606 184 0125 Otros: 606 184 0225 VIANO 2.3 TD</p>
	<p>RA-7031</p> <p>Øext.: 92 FORD 1025629, 95 VW6714AB Øint.: 35 VW GOL GTI 2,8 i VRG - GOLF H.: 58 V.A.G. 021 115 561 B, 021 115 562AB Otros: AUDI A8 4,2 V 8 / JEEP CHEROKEE > 00</p>
	<p>RA-7032</p> <p>Øext.: 52,5 FORD 1100696, XM216744AA Øint.: 24 - 24 AUDI A3 TD 1,9 i - VW POLO - GOLF H.: 87 PASSAT - SEAT CORDOBA-TOLEDO 1,9 TDI Otros: V.A.G. 038 115 466, 074 115 562 VW 074115562 BORA 1,9 TDI</p>
	<p>RA-7033</p> <p>Øext.: 59 MERCEDES BENZ Øint.: 13,4 - 22 104 180 0109 - 104 184 0225 H.: 140,6 104 184 0325 - 104 184 0425 Otros: 104 184 0825 - 00A 115 466</p>
	<p>RA-7037</p> <p>Øext.: 62 MERCEDES BENZ 166 180 0009 Øint.: 31 166 180 0109 - CLASE A160 H.: 116 166 180 0710 - 166 184 0525 Otros: CLASE A 160 1,61 8 V</p>
	<p>RA-7038</p> <p>Øext.: 91,5 - 52 MERCEDES BENZ 001 184 9425 Øint.: 35 - 32 611 180 0009 C220 CDI - TD H.: 91 - 85 112 180 0009 - 112 184 0025 OM-611 Otros: SPRINTER 311 - 313 - 413 E270 OM-611 - LAREDO 2,7</p>
	<p>RA-7043</p> <p>Øext.: 90 - 92 AGCO DEUTZ TRACTOR 6.125 Øint.: 11,4 - 25 Nº 0293-1093 H.: 196 MERCEDES BENZ 906-1800009 Otros: RENAULT 50018469993</p>
	<p>RA-7044</p> <p>Øext.: 92 - 90 GM 90570368 - 90544191 Øint.: 11,4 - 24,4 9117321 - 90540460 H.: 169 OPEL 5650319 - SAAB4772166 Otros: VECTRA - ASTRA TD - ZAFIRA</p>
	<p>RA-7049</p> <p>Øext.: 61 GM 90536362 - 9192426 Øint.: 35 - 9,8 5650316 - 650308 - OPEL H.: 89 GM 21018826 Otros: CORSA NAFTERO 1,8 651</p>
	<p>RA-7061</p> <p>Øext.: 83 GM 97223218 - ISUZU 897223170 Øint.: 11 - 40 OPEL 650300 - MERIVA H.: 178 HONDA 15430-PLZ-D00 Otros: CORSA GL / GLX 1,7 CDTI - CORSA II D</p>
	<p>RA-7065</p> <p>Øext.: 84 BMW 11427512301 - 11427512300 Øint.: 23 - 30 11427509,430 - 11421740 534 H.: 106 11421427908 - 7509430 Otros: BMW 328 i, 328 i CABRIO 23 COUPE 525 i - 523 i</p>
	<p>RA-7066</p> <p>Øext.: 120 BMW 11 42 2 246 131 Øint.: 14 - 55 11 42 2 246 135 525 H.: 147 GM 90542604 - 5650307 - 5650308 Otros: LAND ROVER STC 3350</p>
	<p>RA-7070</p> <p>Øext.: 120 - 45 MERCEDES BENZ 1938 A Øint.: 58 ELECTRÓNICO H.: 316 4571800009 - A4511840225 Otros:</p>
	<p>RA-7070x</p> <p>Øext.: 121 - 45 MERCEDES BENZ 2340 Øint.: 58 - 14 0001802109 - 4571840125 H.: 264 - 251 Otros:</p>
	<p>RA-7073</p> <p>Øext.: 72 - 65,5 FIESTA - ECO ESPORT 1,4 D Øint.: 20 - 26 C3 D - 307 SW H.: 99 Otros:</p>
	<p>RA-7090</p> <p>Øext.: 64 FORD 3M5Q-6744AA 1303478 Øint.: 29 CITROËN 1109-X4 / 1109-Z2 H.: 69 PEUGEOT 1109-X3 / 1109-Z1 Otros: VOLVO 30650798 - C3 1.6 05-> PARTNER 1,4 PEUGEOT 307 2,0 16V</p>
	<p>RA-7091</p> <p>Øext.: 64 AUDI A3 - VW PASSAT (3C2/3C5) Øint.: 31 VENTO - VW 06D 115 466 H.: 125 06D 115 562 - 06D 198 405 VENTO 2,5 Otros:</p>
	<p>RA-7095</p> <p>Øext.: 83 FORD RANGER 3.0 ORIGINAL 71180 Øint.: 34 L200 3.0 Tdi - FRONTIER Tdi H.: 150 Otros:</p>
	<p>RA-7103</p> <p>Øext.: 102 - 98 SCANIA R500 EURO 3 Øint.: 44 1439036 / 1873014 H.: 253 Otros:</p>
	<p>RA-7120</p> <p>Øext.: 83 AGCO - DEUTZ 6.110 Øint.: 28 - 37 - CIEGO Nº 02931092 H.: 149,5 04208014 - 4208014 Otros:</p>



RC-7113

Øext.: 84 - 62 TOYOTA 3000 - 23390-0L010
 Øint.: 22,3 - 9 (ROLLER PAPER)
 H.: 76 N° 23300-0L020
 Otros: DENSO 1860400010



RC-7601

Øext.: 90 - 95 MERCEDES BENZ 1938 L LS
 Øint.: 14 - 46 INYECCIÓN ELEC.
 H.: 205
 Otros:

RC



RC-7602

Øext.: 77 MERCEDEZ BENZ C 220 CDI
 Øint.: 18,5 - 26 MOTOR OM 611
 H.: 90
 Otros:



RA-7603

Øext.: 92 MERCEDEZ BENZ 712 C- 914C
 Øint.: 45 - 28 MOTOR OM-904 OM-906
 H.: 103 MB- A9060920305
 Otros: MB 1624 ELECT. / CLASS

















RC-7615















Øext.: 84 SCANIA 1873018
 Øint.: 38 1429059 / 1446432
 H.: 180 - 162
 Otros:

CB

	<p>CB-5001 SISTEMAS HIDRÁULICOS RETORNO</p> <p>Entrada/Salida: Cabezal de aluminio 1 1/4" NPT con válvula By-pass 25 PSI Rosca filtro: RETORNO. 1 1/4" x 11 BSP 1 1/2" x 16 UNF</p>
	<p>CB-5002 SISTEMAS HIDRÁULICOS</p> <p>Entrada/Salida: Cabezal de aluminio 1 1/2" NPT con válvula By-pass 28 PSI Rosca cabezal: M 45 x 1,5</p>
	<p>CB-5003 MULTIUSO</p> <p>Entrada/Salida: Cabezal de aluminio 1 1/2" NPT Rosca filtro: 1 1/2" x 16 UNF</p>
	<p>CB-5004 MULTIUSO</p> <p>Entrada/Salida: Cabezal de aluminio 3/4" NPT con soporte de fijación. Rosca filtro: BL-2088, BL-2127 1 1/8" x 16 UNF HF-3052</p>
 <small>INCLUYEN 2 TAPONES DE M 14 X 1,5 Y ARANDELAS DE ALUMINIO</small>	<p>CB-5005 COMBUSTIBLE FLUJO NORMAL</p> <p>Doble Entrada/Salida: Cabezal de aluminio M 14 x 1,5 con soporte de fijación. Rosca filtro: BR-1032, BR-1090 7/8" x 14 UNF (acero) BR-1099, BR-1188</p>
 <small>INCLUYEN 2 TAPONES DE M 14 X 1,5 Y ARANDELAS DE ALUMINIO</small>	<p>CB-5006 COMBUSTIBLE FLUJO NORMAL</p> <p>Doble Entrada/Salida: Cabezal de aluminio M 14 x 1,5 con soporte de fijación. Rosca filtro: BR-1037, BR-1094 P 3/4" x 16 UNF (acero) BR-1022, BR-1178</p>
 <small>INCLUYEN 2 TAPONES DE M 14 X 1,5 Y ARANDELAS DE ALUMINIO</small>	<p>CB-5007 COMBUSTIBLE FLUJO NORMAL</p> <p>Doble Entrada/Salida: Cabezal de aluminio M 14 x 1,5 con soporte de fijación. Rosca filtro: BR-1027, BR-1071P, BR-1123P 1" x 14 UNF (acero) BR-1100P, BR-1075, BR-1242H, BR-1047P, BR-45P/1, BR-60P/1 BR-90P/1, LINEA BR-1145H</p>
 <small>INCLUYEN 2 TAPONES DE M 14 X 1,5 Y ARANDELAS DE ALUMINIO</small>	<p>CB-5008 COMBUSTIBLE FLUJO NORMAL</p> <p>Doble Entrada/Salida: Cabezal de aluminio M 14 x 1,5 con soporte de fijación. Rosca filtro: BR-90PM, BR-120PM, BR-1046P 1" x 12 UNF (acero) LINEA BR-90HM, BR-120HM</p>
	<p>CB-5009</p> <p>Entrada/Salida: Cabezal con soporte 3/4 x 16 UNF de fijación para Rosca filtro: aceite (en derivación). 1 3/8" x 16 UNF LFP-777B</p>
	<p>CB-5010</p> <p>Entrada/Salida: Cabezal de aluminio 3/4" NPT con soporte de fijación. Rosca filtro: BR-60 P, BR-90 P, 1" x 14 UNF BR-1123 P</p>
	<p>CB-5011 MULTIUSO</p> <p>Entrada/Salida: Cabezal de aluminio 1 1/4" NPT Rosca filtro: 1 1/4" x 11 BSP 1 1/2" x 16 UNF</p>
	<p>CB-5013 MULTIUSO</p> <p>Entrada/Salida: Cabezal de aluminio. 1 1/2" NPT Rosca filtro: BR-1085 1 1/2" x 16 UNF</p>
	<p>CB-5014 MULTIUSO</p> <p>Entrada/Salida: Cabezal de aluminio. 1" x 11 BSP HF-3048, HF-3085, HF-3135, Rosca filtro: BR-1048 P, BR-1127 1" x 12 UNF</p>
	<p>CB-5015</p> <p>Entrada/Salida: Cabezal de aluminio. 3/4" NPT LFP-8654 Rosca filtro: M 38 x 1,5</p>
 <small>INCLUYEN 2 TAPONES DE M 14 X 1,5 Y ARANDELAS DE ALUMINIO</small>	<p>CB-5016 COMBUSTIBLE FLUJO INVERSO</p> <p>Doble Entrada/Salida: Cabezal de aluminio M 14 x 1,5 con soporte de fijación. Rosca filtro: BR-24 H, BR-26 H, BR-28 H, 1" x 14 UNF (acero) BR-1177 P, BR-1119 H</p>
 <small>INCLUYEN 2 TAPONES DE M 14 X 1,5 Y ARANDELAS DE ALUMINIO</small>	<p>CB-5017 REFRIGERANTES FLUJO NORMAL</p> <p>Doble Entrada/Salida: Cabezal de aluminio M 14 x 1,5 con soporte de fijación. Rosca filtro: LFW-4071, LFW-4073, 11/16" x 16 UNF (acero) LFW-4865</p>
	<p>CB-5018 COMBUSTIBLE</p> <p>Doble Entrada/Salida: Cabezal de aluminio M 14 x 1,5 con soporte de fijación. Roscas filtro: BR-60PF, BR-90PF, BR-1200H, 1" x 14 UNF BR-45P, BR-60P, BR-90P</p>
	<p>CB-5019 COMBUSTIBLE</p> <p>Doble Entrada/Salida: Cabezal de aluminio M 14 x 1,5 con soporte de fijación. Roscas filtro: BR-90 PM, BR-120 PM, 1" x 12 UNF BR-1201 HM</p>
	<p>CB-5020 COMBUSTIBLE</p> <p>Doble Entrada/Salida: Cabezal doble de alum. M 14 x 1,5 con soporte de fijación. Roscas filtros: BR-1101 H + DR-4429 BR-1102 M 20 x 1,5 M 16 x 1,5</p>
	<p>CB-5021 SUCCIÓN</p> <p>Entrada/Salida: Cabezal de aluminio 1 1/4" NPT con válvula By-pass 3 PSI. Rosca filtro: 1 1/4" x 11 BSP 1 1/2" x 16 UNF</p>

	<p>CB-5023 COMBUSTIBLE</p> <p>Doble Entrada/Salida: Cabezal doble de alum. con soporte de fijación. BR-1034 P, BR-1102</p> <p>Rosca filtro: M 16 x 1,5</p>
	<p>CB-5024</p> <p>Entrada/Salida: Cabezal de hierro alta presión. 1" x 11 1/2 NPT</p> <p>Rosca filtro: 1" x 12 UNF</p>
	<p>CB-5025</p> <p>Entrada/Salida: Cabezal de hierro alta presión. 1/2 NPT</p> <p>Rosca filtro: 1" x 12 UNF</p>
	<p>CB-5026 COMBUSTIBLE</p> <p>Doble Entrada/Salida: Cabezal doble de alum. con soporte de fijación. BR-1043, BR-1094 P</p> <p>Rosca filtro: 3/4 x 16</p>
	<p>CB-5027 MULTIUSO</p> <p>Entrada/Salida: Cabezal de aluminio. HF-3063, HF-3126</p> <p>Rosca filtro: 3/4 x 14 BSPT</p>
	<p>CB-5028 SUCCIÓN</p> <p>Entrada/Salida: Cabezal de aluminio con válvula By-pass. 3/4 x 14 NPT</p> <p>Rosca filtro: 3/4 x 14 BSPT</p>
	<p>CB-5029 RETORNO</p> <p>Entrada/Salida: Cabezal de aluminio con válvula By-pass. 3/4 x 14 NPT</p> <p>Rosca filtro: 3/4 x 14 BSPT</p>
	<p>CB-5030 COMBUSTIBLE FLUJO NORMAL</p> <p>Doble Entrada/Salida: Cabezal de aluminio con soporte de fijación. M 14 x 1,5</p> <p>Rosca filtro: 20 x 1,5 (acero)</p> <p><small>INCLUYEN 2 TAPONES DE M 14 X 1,5 Y ARANDELAS DE ALUMINIO</small></p>
	<p>CB-5031 MULTIUSO</p> <p>Entrada/Salida: Cabezal de aluminio. BR-1048 P, BR-1127, BR-1076, HF-3048 LF, HF-3141, BL-2080</p> <p>Rosca filtro: 1" x 12 UNF</p>
	<p>CB-5032 SUCCIÓN</p> <p>Entrada/Salida: Cabezal de aluminio con válvula By-pass. 1" x 11 BSP</p> <p>Rosca filtro: 1" x 12 UNF</p>
	<p>CB-5033 RETORNO</p> <p>Entrada/Salida: Cabezal de aluminio con válvula By-pass. 1" x 11 BSP</p> <p>Rosca filtro: 1" x 12 UNF</p>
	<p>CB-5034 MULTIUSO</p> <p>Entrada/Salida: Cabezal de aluminio. BR-1075, BR-1071 P, BR-1100 P</p> <p>Rosca filtro: 1" x 14 UNF</p>
	<p>CB-5035 COMBUSTIBLE FLUJO NORMAL</p> <p>Doble Entrada/Salida: Cabezal de aluminio con soporte de fijación. BR-1077</p> <p>Rosca Filtro: 13/16 x 12 UNF (acero)</p> <p><small>INCLUYEN 2 TAPONES DE M 14 X 1,5 Y ARANDELAS DE ALUMINIO</small></p>
	<p>CB-5036 COMBUSTIBLE FLUJO INVERSO</p> <p>Doble Entrada/Salida: Cabezal de aluminio con soporte de fijación. BR-1177 P</p> <p>Rosca Filtro: 1" x 12 UNF (acero)</p> <p><small>INCLUYEN 2 TAPONES DE M 14 X 1,5 Y ARANDELAS DE ALUMINIO</small></p>
	<p>CB-5037 COMBUSTIBLE FLUJO NORMAL</p> <p>Doble Entrada/Salida: Cabezal de aluminio con soporte de fijación. BR-1072 P</p> <p>Rosca Filtro: 13/16 x 18 UNF (acero)</p> <p><small>INCLUYEN 2 TAPONES DE M 14 X 1,5 Y ARANDELAS DE ALUMINIO</small></p>
	<p>CB-5038</p> <p>Entrada/Salida: Cabezal de aluminio. BR-1020 P, BR-1024, BR-1131 P</p> <p>Rosca Filtro: M 16 x 12</p>
	<p>CB-5120</p> <p>Entrada/Salida: Conjunto filtro. Elemento filtrante BR-1024</p> <p>Rosca filtro: M 16 x 1,5</p>
	<p>CB-5121</p> <p>Entrada/Salida: Conjunto filtro con cebador. Elemento filtrante BR-1020</p> <p>unión orientable Ø 8</p> <p>Rosca filtro: M 16 x 1,5</p>
	<p>CB-5122</p> <p>Entrada/Salida: Conjunto filtro. Elemento filtrante BR-1023 sin vaso colector.</p> <p>Rosca filtro: M 14 x 1,5</p>
	<p>CB-5123</p> <p>Entrada/Salida: Conjunto filtro. Elemento filtrante BR-1023 con vaso cónico de vidrio</p> <p>Rosca filtro: M 14 x 1,5</p>

CB

	<p>CB-5124</p> <p>Entrada/Salida: unión orientable Ø 8</p> <p>Conjunto filtro con cebador. Elemento filtrante BR-1023 con vaso cónico de vidrio</p>
	<p>CB-5125</p> <p>Entrada/Salida: M 14 x 1,5</p> <p>Conjunto doble. Elemento filtrante separador primario BR-1020 secundario BR-1024</p>
	<p>CB-5126</p> <p>Entrada/Salida: M 14 x 1,5</p> <p>Conjunto filtro. Elemento filtrante BR-1029 sin vaso colector</p>
	<p>CB-5127</p> <p>Entrada/Salida: M 14 x 1,5</p> <p>Conjunto filtro. Elemento filtrante BR-1029 con vaso cónico de vidrio</p>
	<p>CB-5128</p> <p>Entrada/Salida: unión orientable Ø 8</p> <p>Conjunto filtro con cebador. Elemento filtrante BR-1029 con vaso cónico de vidrio</p>
	<p>CB-5129</p> <p>Entrada/Salida: 1/2 x 20 UNF</p> <p>Conjunto prefiltro. Elemento filtrante PF-586</p>
	<p>CB-5130</p> <p>Entrada/Salida: M 14 x 1,5</p> <p>Conjunto prefiltro. Elemento filtrante malla metálica. Deutz</p>
	<p>CB-5131</p> <p>Doble Entrada/Salida: 1/2 x 20 UNF</p> <p>Conjunto filtro. Elemento filtrante BR-1029 con vaso cónico de vidrio</p>
	<p>CB-5132</p> <p>Entrada/Salida: unión orientable Ø 8</p> <p>Conjunto prefiltro con cebador. Elemento filtrante malla metálica.</p>
	<p>CB-5133</p> <p>Entrada/Salida: 1/2 x 20 UNF</p> <p>Conjunto prefiltro. Elemento filtrante malla metálica. Perkins.</p>
	<p>CB-5134</p> <p>Doble Entrada/Salida: M 14 x 1,5</p> <p>Rosca filtro: 3/4 x 16</p> <p>Conjunto filtro. Elemento filtrante BR-1037 BR-1094 P</p>
	<p>CB-5135</p> <p>Doble Entrada/Salida: M 14 x 1,5</p> <p>Rosca filtro: M 16 x 1,5</p> <p>Conjunto filtro. Elemento filtrante BR-1074</p>
	<p>CB-5136</p> <p>Entrada/Salida: M 14 x 1,5</p> <p>Roscas filtros: M 20 x 1,5 M 16 x 1,5</p> <p>Conjunto doble filtro. Cabezal de aluminio con soporte de fijación. Elemento filtrante BR-1101 H BR-1102</p>
	<p>CB-5137</p> <p>Entrada/Salida: M 14 x 1,5</p> <p>Roscas filtros: M 20 x 1,5 M 16 x 1,5</p> <p>Conjunto doble filtro. Cabezal de aluminio con soporte de fijación. Elementos filtrantes BR-1101 H BR-1073</p>
	<p>CB-5138</p> <p>Entrada/Salida: M 14 x 1,5</p> <p>Roscas filtros: M 20 x 1,5 M 16 x 1,5</p> <p>Conjunto doble filtro. Cabezal de aluminio con soporte de fijación. Elemento filtrante BR-1103 P BR-1073</p>



CP-300/0 1º EF-0431 2º ---
Potencia HP: 45 RENAULT 12 - 18
Caudal m³/min.: 3
Banda de mont.: 1



CP-310/0 1º EF-0424 2º ---
Potencia HP: 52 TRAFFIC DIESEL 1,7
Caudal m³/min.: 3.5 RENAULT
Banda de mont.: 2



CP-345/1 1º EF-0449 2º ---
Potencia HP: 50 PICK UP PEUGEOT
Caudal m³/min.: 3.4 504 DIESEL
Válv. eyectora: SI



CP-450/0 1º EF-0439 2º EF-0433
Potencia HP: 67 DEUTZ F3L913, F4L913
Caudal m³/min.: 4.5 F4L912 - PERKINS 4-203,
Banda de mont.: 1 6-305 - M. BENZ 608



CP-450/1 1º EF-0439 2º EF-0433
Potencia HP: 67 MASSEY FERGUSON
Caudal m³/min.: 4.5 MF-250, MF-255, MF-265
Válv. eyectora: SI JOHN DEERE 440, 350
Banda de mont.: 1



CP-585/0 1º EF-0761 2º ---
Potencia HP: 90 CAMIONES
Caudal m³/min.: 5.8
Banda de mont.: 1



CP-585/1 1º EF-0761 2º ---
Potencia HP: 90 AGRÍCOLA
Caudal m³/min.: 5.8 VIAL
Válv. eyectora: SI
Banda de mont.: 1



CP-585/2 1º EF-0761 2º ---
Potencia HP: 90 FORD RANGER TDIC
Caudal m³/min.: 5.8 MAXION 2.5
Válv. eyectora: SI REEMP. FILTRO PANEL
Banda de mont.: 1



CP-600/0 1º EF-0440 2º EF-0434
Potencia HP: 90 DEUTZ F4L913, F5L913
Caudal m³/min.: 6 PERKINS 6PF 305
Banda de mont.: 1 M. BENZ MOTOR OM-364
VALMET 885



CP-600/1 1º EF-0440 2º EF-0434
Potencia HP: 90 DEUTZ F4L913, F5L913
Caudal m³/min.: 6 PERKINS 6PF 305
Válv. eyectora: SI M. BENZ MOTOR OM-364
Banda de mont.: 1 VALMET 885



CP-750/0 1º EF-0723 2º EF-0724
Potencia HP: 110 CAMIONES
Caudal m³/min.: 7.5 AGRÍCOLAS
Banda de mont.: 1



CP-750/2 1º EF-0723 2º EF-0724
Potencia HP: 110 CHEVROLET SILVERADO STD
Caudal m³/min.: 7.5 MAXION 4.1 - MWM 4.2
Banda de mont.: 1 REEMP. FILTRO PANEL



CP-750/3 1º EF-0723 2º EF-0724
Potencia HP: 110 REEMP. FILTRO
Caudal m³/min.: 8 AIRE TRACTOR A-85



CP-800/0 1º EF-0441 2º EF-0435
Potencia HP: 120 DEUTZ F6L913, F8L413
Caudal m³/min.: 8 PERKINS 6-354
Banda de mont.: 1 M. BENZ MOTOR OM-1214
OM-364



CP-800/1 1º EF-0441 2º EF-0435
Potencia HP: 120 JOHN DEERE 5600, 6300
Caudal m³/min.: 8 M. FERGUSON 1175,
Válv. eyectora: SI 1185, 1475
Banda de mont.: 1 VALMET 885TS, 1280



CP-1200/0 1º EF-0443 2º EF-0436
Potencia HP: 180 DEUTZ BF6L913
Caudal m³/min.: 12 M. BENZ MOTOR OM-366 A
Banda de mont.: 1 PERKINS 6-354



CP-1200/1 1º EF-0443 2º EF-0436
Potencia HP: 180 V-8 540
Caudal m³/min.: 12 M. FERGUSON 1615
Válv. eyectora: SI 1215, 5140
Banda de mont.: 1 VALMET 985, 8050, 11805



CP-1500/1 1º EF-0445 2º EF-0437
Potencia HP: 225 DEUTZ BF-6L913T
Caudal m³/min.: 15 M. BENZ MOTOR OH-1526
Válv. eyectora: SI M. FERGUSON 1640-5650
Banda de mont.: 1



CP-2100/1 1º EF-0447 2º EF-0438
Potencia HP: 315 DEUTZ BF6L513RC
Caudal m³/min.: 21 M. BENZ MOTOR OM-449 LA
Válv. eyectora: SI CUMMINS 6CTA 8.3
Banda de mont.: 2 SCANIA D511



CP-2100/2 1º EF-0447 2º EF-0438
Potencia HP: 315 VASSALLI
Caudal m³/min.: 21 COSECHADORAS
Banda de mont.: 2

CARCAZAS PURIFICADORAS DE AIRE

Metálicas



CP



CP-2100/3 1º EF-0447 2º EF-0438
 Potencia HP: 315 MOTORES VOLVO
 Caudal m³/min.: 21
 Válv. eyectora: SI
 Banda de mont.: 2



CP-2700/0 1º EF-0467 2º EF-0707
 Potencia HP: 360 COLECTIVOS
 Caudal m³/min.: 27 EL DETALLE OA-105
 Banda de mont.: 2 CUMMINS 6 CTA 8.5



CP-2700/1 1º EF-0467 2º EF-0707
 Potencia HP: 360 AGRÍCOLA
 Caudal m³/min.: 27 VIAL
 Válv. eyectora: SI
 Banda de mont.: 2



CP-4000/0 1º EF-0963 2º EF-0964
 Potencia HP: 600 COSECHADORAS
 Caudal m³/min.: 40 GRUPOS ELECTRÓGENOS
 Banda de mont.: 2



CP-4000/2 1º EF-0963 2º EF-0964
 Potencia HP: 600 COSECHADORAS
 Caudal m³/min.: 40 GRUPOS ELECTRÓGENOS
 Válv. eyectora: SI
 Banda de mont.: 2



CP-4000/3 1º EF-0963 2º EF-0964
 Potencia HP: 600 COSECHADORAS
 Caudal m³/min.: 40 GRUPOS ELECTRÓGENOS
 Banda de mont.: 2

CURVA CARACTERÍSTICA PARA DIFERENTES CAUDALES

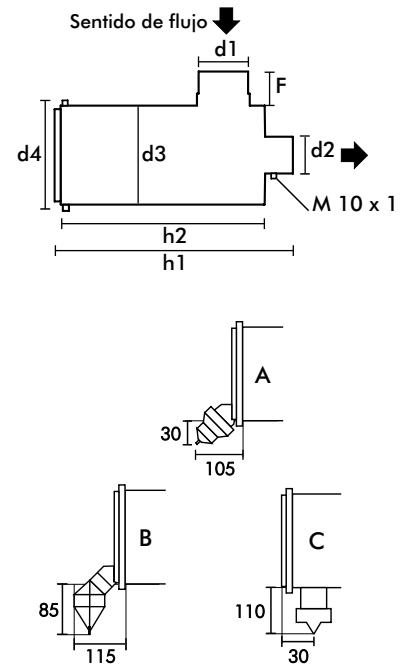
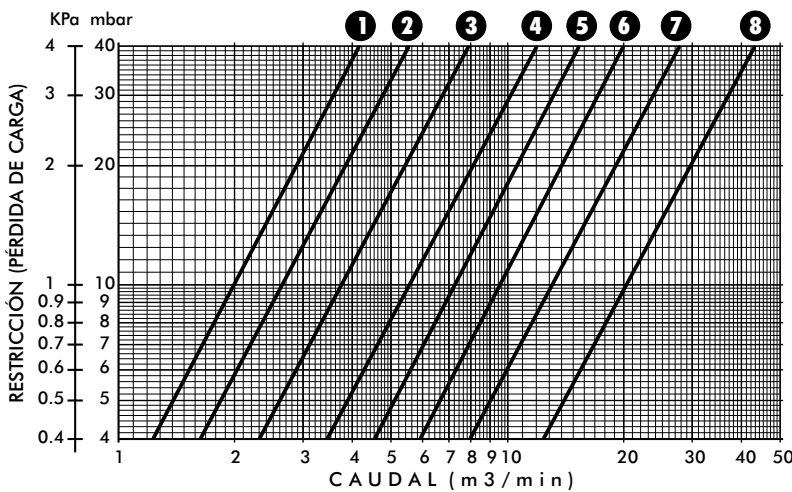

MEDIDAS CARCAZAS

	1	2	3	4	5	6	7	8							
MODELO	CP300/0	CP310	CP345/1	CP450/1	CP585/2	CP600/1	CP750/2	CP800/1	CP1200/1	CP1500/1	CP2100/1	CP2700/1	CP4000/0	CP4000/2	CP4000/3
d1	70	70	63	63	82	68	100	82	102	110	132	150	203	203	152
d2	63	63	60	60	78	70	64	82	102	110	132	150	203	152	152
d3	162	162	165	165	210	195	235	215	255	290	310	375	444,5	444,5	444,5
d4	180	180	180	180	230	208	243	230	270	308	325	393	447	447	447
h1	285	380	304	385	340	435	420	465	485	515	615	600	748	748	748
h2	185	315	227	310	275	352	240	370	395	405	527	505	678	678	678
F	40	40	35	35	21	40	45	55	65	65	67	85	85	85	85
Tipo	A	A	A	A	A	A	A	B	B	B	C	C	C	C	C



CP-0027/0 1º EF-0427 2º ---
 Caudal m³/min.: 2 COMPRESORES
 Medidas: GENERADORES
 VARIOS

Fig. N°	A	B	C
1	50	162	160



CP-0030/0 1º EF-0432 2º ---
 Caudal m³/min.: 4 FORD F-100
 Medidas: ECONO 6
 (CARBURADOR HOLLEY)

Fig. N°	A	B	C
2	63	302	100

CP



CP-0030/1 1º EF-0432 2º ---
 Caudal m³/min.: 4 FORD F-100 - V8
 Medidas: (8 CILINDROS
 NAFTERO)

Fig. N°	A	B	C
3	129	302	112



CP-0030/2 1º EF-0432 2º ---
 Caudal m³/min.: 4 FORD F-100
 Medidas: MOTORES PERKINS
 3-152, 4-203, 6-305

Fig. N°	A	B	C
4	58	302	135





CP-0030/3 1º EF-0432 2º ---
 Caudal m³/min.: 4 FORD CIMARRON
 Medidas: 3300 D, 3800 D

Fig. N°	A	B	C
4	80	302	150

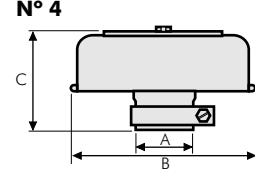
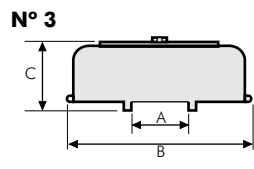
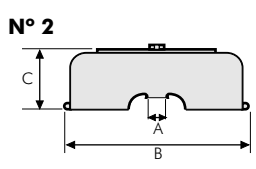
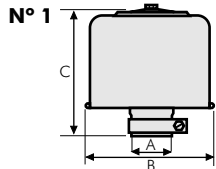

CP-0030/4 1º EF-0432 2º ---
 Caudal m³/min.: 4 COMPRESORES
 Medidas: VARIOS

Fig. N°	A	B	C
4	76	302	150

CP-0432/0 1º EF-0432 2º ---
 Caudal m³/min.: 4 FORD F-100 MOTOR PERKINS
 Medidas: 3-152, 4-203, 6-305

Fig. N°	A	B	C	D
1	58	328	140	76



CP-0432/1 1º EF-0432 2º ---
 Caudal m³/min.: 4 FORD CIMARRON
 Medidas: 3300 D, 3800 D

Fig. N°	A	B	C	D
1	80	328	155	76



CP-0432/2 1º EF-0432 2º ---
 Caudal m³/min.: 4 FORD F-100 ECONO 6
 Medidas: (CARBURADOR HOLLEY)

Fig. N°	A	B	C	D
2	63	328	115	76



CP-0432/3 1º EF-0432 2º ---
 Caudal m³/min.: 4 FORD F-100 V-8
 Medidas: (8 CILINDROS
 NAFTERO)

Fig. N°	A	B	C	D
3	129	328	120	76



CP-0432/4 1º EF-0432 2º ---
 Caudal m³/min.: 4 GENERADORES
 Medidas: COMPRESORES
 VARIOS

Fig. N°	A	B	C	D
1	76	328	155	76





CP-0514/0 1º EF-0514 2º EF-0515
 Caudal m³/min.: 7 FORD - DODGE
 Medidas: MOT. PERKINS
 6-354, 6-354 T

Fig. N°	A	B	C	D
4	76	432	190	80

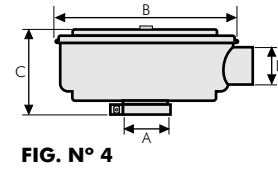
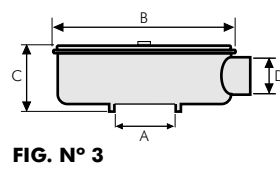
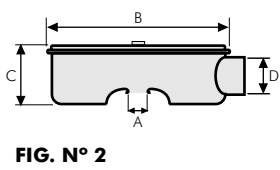
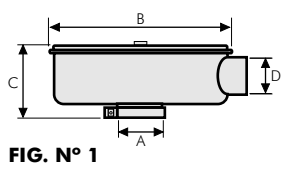

CP-0514/1 1º EF-0514 2º EF-0515
 Caudal m³/min.: 7 MERCEDES BENZ
 Medidas: 1112 - 1114

Fig. N°	A	B	C	D
4	80	432	190	80

FAR-156
 Caudal m³/min.: 1
 Ø de Salida: 40 mm
 Con Filtro



FAR-156
 Caudal m³/min.: 2
 Ø de Salida: 52 mm
 Con Filtro

FAR

FR



RADIALPAC

UN NUEVO CONCEPTO EN CARCAZAS PARA AIRE

Filtros LANSS incorpora la nueva generación de filtros para aire de sello radial. Fabricados en plástico, flexible para asegurar una estanqueidad altamente eficaz. Cuenta con 9 modelos que van de 2 a 28m³/min de caudal nominal, cubriendo todo tipo de requerimiento: maquinaria agrícola-vial, transporte, compresores, generadores, motores marinos y otros.

- LIVIANO
- RESISTENTE A LA CORROSIÓN
- COMPACTOS
- FÁCIL INSTALACIÓN

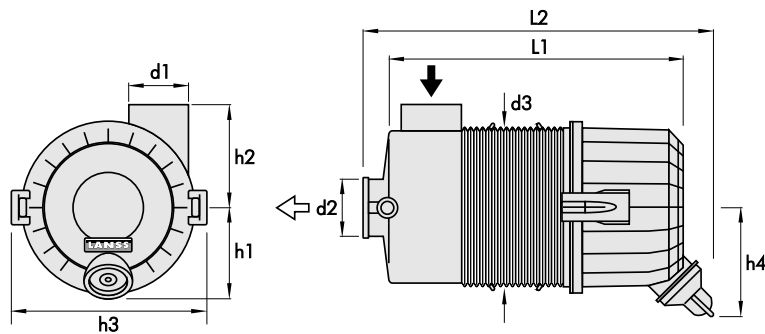

MEDIDAS CARCAZAS

	1	2	3	4	5	6	7	8	9
MODELO	FR04	FR05	FR06	FR07	FR08	FR09	FR10	FR12	FR15
Caudal m³/min	2	3	4	5	8	11	12	21	28
Potencia (HP)	30	45	60	75	120	165	180	315	420
d1	50	51	63	76	95	114	114	152	178
d2	45	52	63	76	90	102	102	127	152
d3	122	146	175	184	212	242	268	309	394
h1	76	87	114	105	119	139	152	173	212
h2	83	100	112	115	130	170	185	204	245
h3	153	180	207	218	247	276	302	344	427
h4	81	107	121	125	139	155	168	173	229
L1	190	302	317	332	357	399	425	500	530
L2	233	357	373	387	414	470	502	560	602
Filtro 1°	EF-932 R	EF-934 R	EF-708 R	EF-735 R	EF-732 R	EF-940 R	EF-746 R	EF-938 R	EF-806 R
Filtro 2°	EF-933 R	EF-935 R	EF-903 R	EF-736 R	EF-733 R	EF-941 R	EF-745 R	EF-939 R	EF-807 R
ABRAZADERA	CF04	CF05	CF06	CF07	CF08	CF09	CF10	CF12	CF15

CURVA CARACTERÍSTICA PARA DIFERENTES CAUDALES

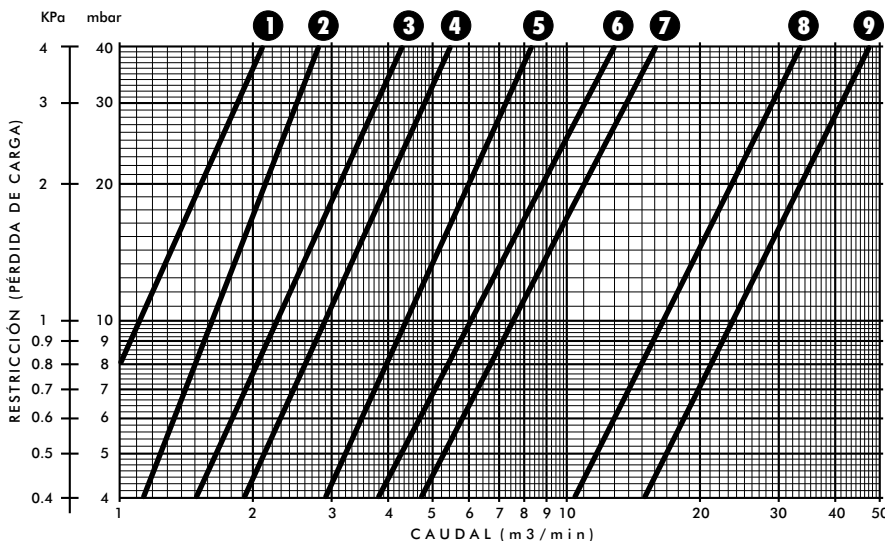

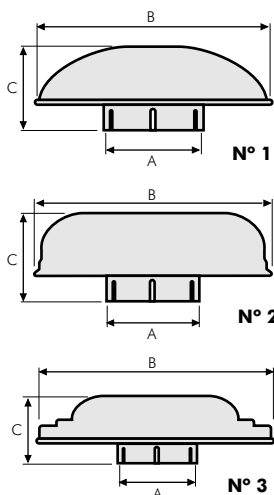

SOMBRETES PARA FILTROS DE AIRE

PARTE N°	FIG. N°	A	B	C
SO-0063	1	63	145	90
SO-0068	1	68	145	90
SO-0076	1	76	200	121
SO-0082	1	82	200	121
SO-0101	1	101	250	145
SO-0110	1	110	250	145
SO-0127	2	127	299	150
SO-0132	1	132	300	180
SO-0152	3	152	373	162

SO

BENEFICIOS DIRECTOS DE PRE FILTROS LANSS®

- **95% de eficiencia.** Evita la entrada al sistema de aire de agua, polvo, nieve y otros contaminantes
- **Prolonga la vida del motor**
- **Reduce el consumo de aceite y combustible**
- **Prolonga la vida de los elementos de aire**
- **Reduce costos de mantenimiento**
- **Autolimpiante** (no necesita mantenimiento de limpieza)
- **Instalación simple y rápida**
- **Funciona por el flujo de aire de admisión**
- **Aplicable a todo tipo de filtro de aire** (seco o en baño de aceite)

TURBO EJECTOR®

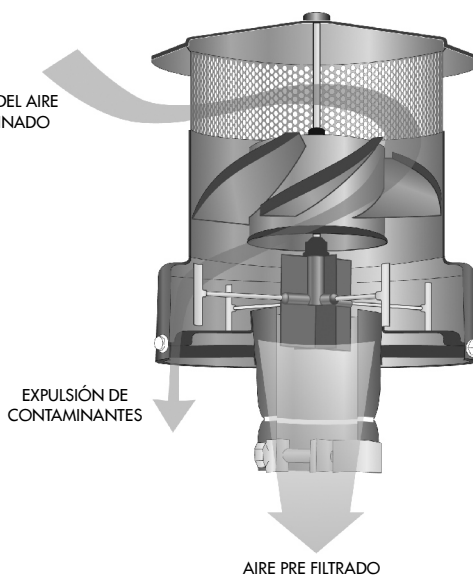

TJ

Cálculo para la selección de un prefiltro

Conversión

Cilindrada (cm³) x 0,06102 = Cilindrada Pulg³

Cilindrada (litro) x 61,02 = Cilindrada Pulg³

RPM: Revoluciones Por Minutos

CF: Motor de 4 tiempos diesel o gasolina = 2

Motor de 2 tiempos diesel o gasolina = 1

EV: Eficaz Volumétrico para motor de 4 tiempos

- Aspiración natural = 0,85

- Turbo alimentado = 1,40

- Turbo alimentado post enfriado = 1,60

EV: Eficaz Volumétrico para motor de 2 tiempos

- Barrido por soplado = 1,4

- Turbo alimentado = 1,9

- Turbo alimentado post enfriado = 2,10

RESTRICCIÓN VS. TIEMPO

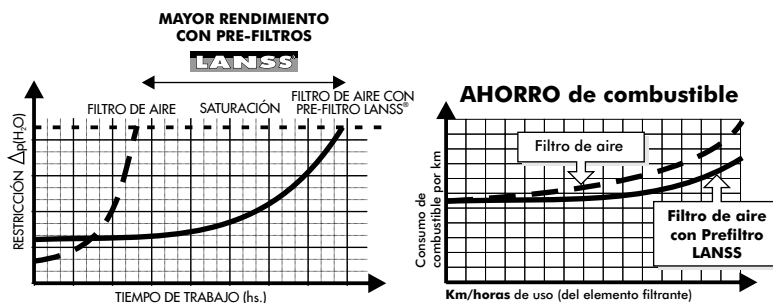

CÁLCULO DEL CAUDAL

$$\text{Aire pie}^3/\text{min} = \frac{\text{Cilindrada(Pulg}^3\text{)}}{1728} \times \frac{\text{RPM}}{\text{CF}} \times \text{EV}$$

PREFILTROS DE AIRE

Metálicos

TJ

TURBO EJECTOR.

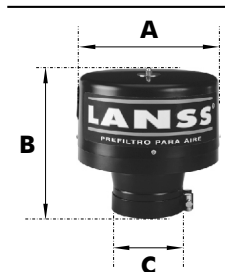

MODELO	DIÁMETRO EXTERIOR (A) - mm	ALTURA TOTAL (B) - mm	DIÁMETROS BOCA DE SALIDA (C) - mm	RANGO OPERACIONAL		
				POTENCIA (HP)	CAUDAL DE AIRE	
					pie ³ /min	m ³ /min
TJ - 250/0	200	290	70	45 a 105	100 a 250	2,8 a 7,0
TJ - 250/1	200	290	76	45 a 105	100 a 250	2,8 a 7,0
TJ - 250/2	200	290	80	45 a 105	100 a 250	2,8 a 7,0
TJ - 250/3	200	290	82	45 a 105	100 a 250	2,8 a 7,0
TJ - 250/4	200	290	89	45 a 105	100 a 250	2,8 a 7,0
TJ - 250/6	200	290	95	45 a 105	100 a 250	2,8 a 7,0
TJ - 250/5	200	290	102	45 a 105	100 a 250	2,8 a 7,0
TJ - 350/0	228	315	76	105 a 150	250 a 350	7,0 a 10,0
TJ - 350/2	228	315	82	105 a 150	250 a 350	7,0 a 10,0
TJ - 350/3	228	315	89	105 a 150	250 a 350	7,0 a 10,0
TJ - 350/4	228	315	102	105 a 150	250 a 350	7,0 a 10,0
TJ - 350/6	228	315	110	105 a 150	250 a 350	7,0 a 10,0
TJ - 350/5	228	315	114	105 a 150	250 a 350	7,0 a 10,0
TJ - 530/0	260	335	102	150 a 220	350 a 530	10,0 a 15,0
TJ - 530/1	260	335	110	150 a 220	350 a 530	10,0 a 15,0
TJ - 530/2	260	335	114	150 a 220	350 a 530	10,0 a 15,0
TJ - 530/3	260	335	127	150 a 220	350 a 530	10,0 a 15,0
TJ - 530/4	260	335	132	150 a 220	350 a 530	10,0 a 15,0
TJ - 700/0	295	425	102	220 a 300	530 a 700	15,0 a 20,0
TJ - 700/1	295	425	110	220 a 300	530 a 700	15,0 a 20,0
TJ - 700/2	295	425	114	220 a 300	530 a 700	15,0 a 20,0
TJ - 700/3	295	425	127	220 a 300	530 a 700	15,0 a 20,0
TJ - 700/4	295	425	132	220 a 300	530 a 700	15,0 a 20,0
TJ - 700/5	295	425	152	220 a 300	530 a 700	15,0 a 20,0
TJ - 700/7	295	425	165	220 a 300	530 a 700	15,0 a 20,0
TJ - 700/6	295	425	178	220 a 300	530 a 700	15,0 a 20,0
TJ - 1100/0	358	517	127	300 a 465	700 a 1100	20,0 a 31,0
TJ - 1100/5	358	517	132	300 a 465	700 a 1100	20,0 a 31,0
TJ - 1100/1	358	517	152	300 a 465	700 a 1100	20,0 a 31,0
TJ - 1100/2	358	517	178	300 a 465	700 a 1100	20,0 a 31,0
TJ - 1100/3	358	517	203	300 a 465	700 a 1100	20,0 a 31,0
TJ - 1100/4	358	517	229	300 a 465	700 a 1100	20,0 a 31,0
TJ - 160/0	138	187	63	33 a 67	90 a 160	2,6 a 4,5
TJ - 160/1	138	187	68	33 a 67	90 a 160	2,6 a 4,5
TJ - 160/2	138	187	76	33 a 67	90 a 160	2,6 a 4,5
TJ - 270/0	206	230	76	67 a 112	160 a 270	4,5 a 7,5
TJ - 270/1	206	230	80	67 a 112	160 a 270	4,5 a 7,5
TJ - 270/2	206	230	82	67 a 112	160 a 270	4,5 a 7,5
TJ - 270/4	206	230	102	67 a 112	160 a 270	4,5 a 7,5
TJ - 270/3	206	230	89	67 a 112	160 a 270	4,5 a 7,5
TJ - 380/0	261	267	102	112 a 180	270 a 430	7,5 a 12,0
TJ - 380/1	261	267	110	112 a 180	270 a 430	7,5 a 12,0
TJ - 380/2	261	267	114	112 a 180	270 a 430	7,5 a 12,0
TJ - 380/3	261	267	127	112 a 180	270 a 430	7,5 a 12,0
TJ - 380/4	261	267	132	112 a 180	270 a 430	7,5 a 12,0
TJ - 680/2	300	275	127	180 a 300	440 a 710	12,5 a 20,5
TJ - 680/0	300	275	132	180 a 300	440 a 710	12,5 a 20,5
TJ - 680/1	300	275	152	180 a 300	440 a 710	12,5 a 20,5

Próximamente estarán disponibles nuevos productos.

TURBO EJECTOR

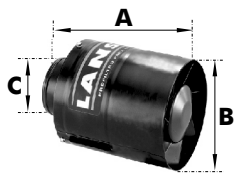

Instalación bajo capot

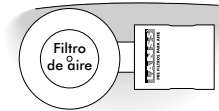

Con banda montaje



Instalación bajo capot

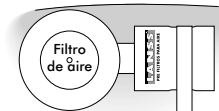

MODELO	DIÁMETRO EXTERIOR (A) - (mm)	ALTURA TOTAL (B) - (mm)	DIÁMETRO BOCA SALIDA (C) - (mm)	RANGO OPERACIONAL		
				POTENCIA (HP)	CAUDAL DE AIRE	
					pie ³ /min	m ³ /min
TJ - 200/0	135	180	63	82	88 a 200	2,5 a 5,5
TJ - 200/3	135	180	68	82	88 a 200	2,5 a 5,5
TJ - 200/6	135	180	76	82	88 a 200	2,5 a 5,5
TJ - 300/5	180	218	76	80 a 130	200 a 300	5,5 a 8,5
TJ - 300/4	180	218	80,5	80 a 130	200 a 300	5,5 a 8,5
TJ - 300/0	180	218	89	80 a 130	200 a 300	5,5 a 8,5
TJ - 300/3	180	218	102	80 a 130	200 a 300	5,5 a 8,5
TJ - 400/0	240	265	102	130 a 225	300 a 530	8,5 a 15
TJ - 400/2	240	265	110	130 a 225	300 a 530	8,5 a 15
TJ - 200/1	135	180	63	82	88 a 200	2,5 a 5,5
TJ - 200/5	135	180	68	82	88 a 200	2,5 a 5,5
TJ - 200/4	135	180	76	82	88 a 200	2,5 a 5,5
TJ - 300/9	180	218	76	80 a 130	200 a 300	5,5 a 8,5
TJ - 300/1	180	218	80,5	80 a 130	200 a 300	5,5 a 8,5
TJ - 300/8	180	218	82	80 a 130	200 a 300	5,5 a 8,5
TJ - 300/6	180	218	89	80 a 130	200 a 300	5,5 a 8,5
TJ - 300/7	180	218	102	80 a 130	200 a 300	5,5 a 8,5
TJ - 400/1	240	265	101	130 a 225	300 a 530	8,5 a 15
TJ - 400/3	240	265	110	130 a 225	300 a 530	8,5 a 15
TJ - 400/4	240	265	132	130 a 225	300 a 530	8,5 a 15

TJ

PREFILTROS PLÁSTICO



TJ-0071

Caudal m³/min.: 2
Ø Acople (mm): 38



TJ-0357

Caudal m³/min.: 5 a 10
Ø Acople (mm): 102

INDICADORES DE MANTENIMIENTO (FILTROS DE AIRE)

MINI-INDICADOR MANUAL

PARTE N°	RESTRICCIÓN LÍMITE
XI-2250	15" H ₂ O
XI-2251	20" H ₂ O
XI-2252	25" H ₂ O
XI-2254	30" H ₂ O

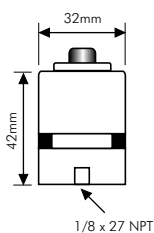

ELÉCTRICO

PARTE N°	RESTRICCIÓN LÍMITE
XI-0500	19" H ₂ O
XI-0650	25" H ₂ O
XI-0813	32" H ₂ O

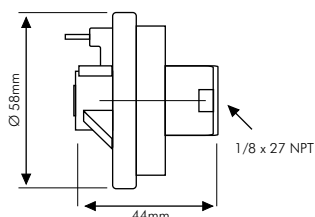

MANÓMETRO

PARTE N°	RESTRICCIÓN LÍMITE		
XI-4435	2 Kg/cm ²	A	1/8 BSPT
XI-4436	2 Kg/cm ²	B	1/8 BSPT
XI-4437	4 Kg/cm ²	B	1/8 BSPT
XI-4495	4 Kg/cm ²	A	1/4 BSPT
XI-4438	7 Kg/cm ²	B	1/8 BSPT

VACUÓMETRO

PARTE N°	RESTRICCIÓN LÍMITE		
XI-4439	0-30" H ₂ O	B	1/8 BSPT

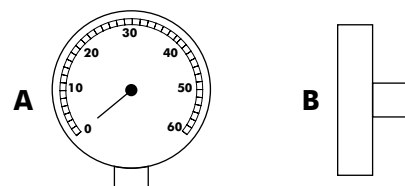

**VASOS CON PURGADOR PARA FILTROS
DE COMBUSTIBLE SEPARADORES DE AGUA**

	DR-4429 VASOS C/PURGADOR ROSCA M 32x2,5 APLICACIÓN: BR-24 H / BR-26 H / BR-28 H / BR-1242 H	DR-4455 VASO 32x2,5 y ROSCA SENSOR 1/2 x 20 UNF
--	--	---

	DR-4465 RECIPIENTE M 95 x 2,5 C/ TAPÓN ROSCA SENSOR 1/2 x 20 UNF Aplic.: LINEA L1	DR-4473 RECIPIENTE M 95 x 2,5 S/ROSCA SENSOR Aplic.: LINEA L1
--	---	--

	DR-4477 RECIPIENTE ALUMINIO M 95 x 2,5 S/ROSCA SENSOR Aplic.: LINEA L1
--	---

	DR-4477 RECIPIENTE ALTA RESISTENCIA TRANSPARENTE PARA L900H / L1000H / LCS-2001
--	---

	DR-4478 RECIPIENTE ALTA RESISTENCIA TRANSPARENTE C/ TAPÓN PARA SENSOR (1/2 x 20) PARA L900H / L1000H / LCS-2001
--	--

**SENSORES DE AGUA PARA FILTROS
DE COMBUSTIBLE**

	DR-4466 M 10 x 1,5 FORD RANGER - TRANSIT MERCEDES BENZ SPRINTER
--	---

	DR-4467 M 12 x 1,75 CITROËN EVASION - XANTIA - ZX PEUGEOT 206 - 306 - 405 - 406
--	---

	DR-4468 M 8 x 1,25 FIAT DUCATO - IVECO DAILY
--	---

	DR-4469 M 8 x 1,25 FIAT DUCATO
--	---

	DR-4470 M 8 x 1,25 IVECO EURO CARGO - EUROTRUCK
--	--

	DR-4471 M 12 x 1 SCANIA CAMIONES - OMNIBUS
--	---

**EXTRACTOR DE ACEITE DE
CÁRTER PARA ANÁLISIS
DE LABORATORIO**



DS-4401

**RECIPIENTE DE PLASTICO Y
MANGUERA PARA MUESTRA
DE ACEITE DE MOTOR**



DS-4402

**LUBRICANTE PARA
INSTALACION DE FILTRO
DE AIRE SELLO RADIAL**

Peso neto
80 grs.



DS-4410

ABRAZADERAS

PARTE N°	A	PARTE N°	A
DA-4392	110-115	DA-4396	60-75
DA-4393	90-105	DA-4397	35-45
DA-4394	80-95	DA-4398	25-35
DA-4395	70-85	DA-4399	12-26
		DA-4400	10-20



BANDAS DE MONTAJE

PARTE N°	A	B	C	D
DA-4388	135	30	80	8
DA-4389	180	30	80	8
DA-4390	240	30	80	8
DA-4391	170	30	80	8

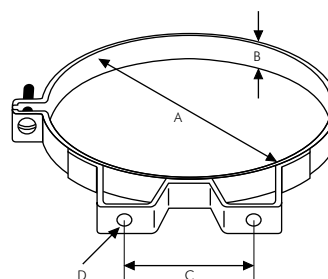

**1) TUBO FLEXIBLE
PARA AIRE**

PARTE N°	DIÁMETRO INTERIOR
DM-4360	60
DM-4361	70
DM-4362	76
DM-4363	80
DM-4364	90
DM-4365	101
DM-4366	110
DM-4367	127
DM-4368	152

**2) MANGUERA OIL PRESS
PARA COMBUSTIBLE - ACEITE**

PARTE N°	DIÁMETRO INTERIOR
DM-4371	8
DM-4372	13
DM-4373	19

**3) MANGUERA PLÁSTICA
FLEXIBLE PARA AIRE**

PARTE N°	DIÁMETRO INTERIOR
DM-4374	63
DM-4375	70
DM-4376	76
DM-4377	82
DM-4378	101

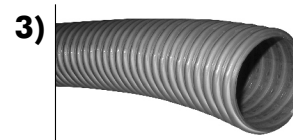

**TUBOS PROLONGADORES METALICOS
CON ABRAZADERA**

PARTE N°	A	B	C
DH-4301	76	76	400
DH-4302	82	82	400
DH-4303	102	102	150
DH-4304	102	102	300
DH-4305	102	102	600
DH-4306	110	110	150
DH-4307	110	110	300
DH-4308	110	110	600
DH-4309	114	114	150
DH-4310	114	114	300
DH-4311	114	114	600
DH-4312	127	127	150
DH-4313	127	127	300
DH-4314	127	127	600
DH-4315	132	132	150
DH-4316	132	132	300
DH-4317	132	132	600
DH-4318	152	152	150
DH-4319	152	152	300
DH-4320	152	152	600
DH-4445	102	102	1000
DH-4446	110	110	1000
DH-4447	127	127	1000
DH-4448	132	132	1000
DH-4449	152	152	1000
DH-4474	203	203	800

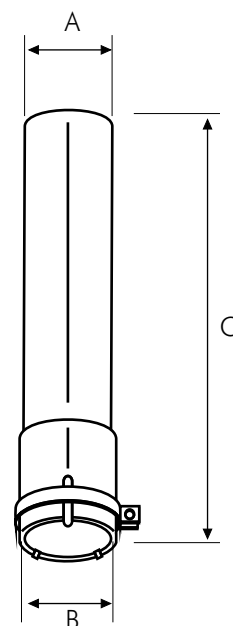

**TUBOS RECTOS METÁLICOS
PARA CONEXIONES**

PARTE N°	A	B
DH-4321	50	400
DH-4322	63	400
DH-4323	70	400
DH-4324	76	400
DH-4325	80	400
DH-4326	102	600
DH-4327	110	600
DH-4328	127	600
DH-4329	132	600
DH-4330	150	600
DH-4451	152	950
DH-4422	102	1000
DH-4423	110	1000
DH-4424	127	1000
DH-4425	132	1000
DH-4426	152	1000

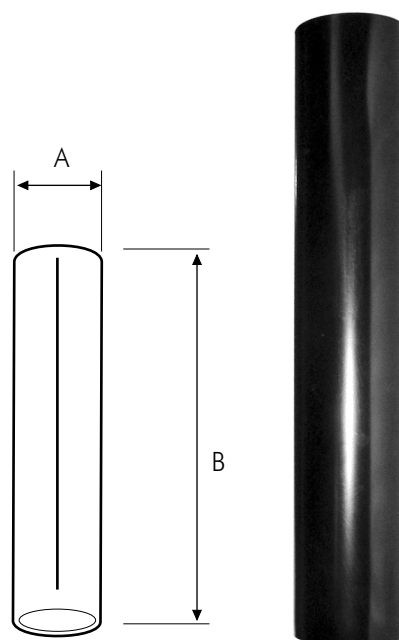

CODOS

PARTE N°	A	B	C	D
DG-4344	101	127	230	230
DG-4347	80	100	200	150
DG-4348	100	110	230	230
DG-4349	90	110	230	230
DG-4359	110	110	230	230
DG-4411	100	100	230	230

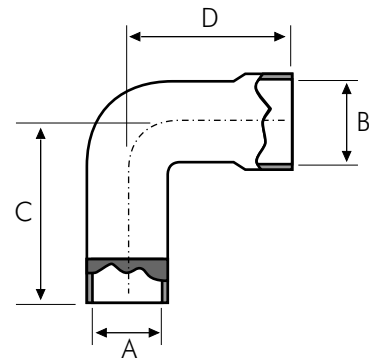

ADAPTADORES PLÁSTICOS

PARTE N°	A	B
XA-P001/0	101	95
XA-P002/0	95	89
XA-P003/0	89	82
XA-P004/0	82	76
XA-P005/0	76	69
XA-P006/0	69	63

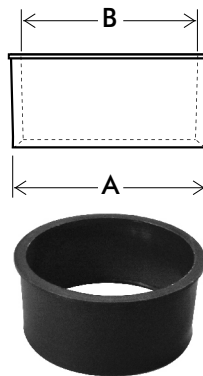

**TUERCA PARA AJUSTE
DE FILTRO
PARA AIRE**



PARTE N°	MEDIDA
DR-4457	7/16 x 20 UNF
DR-4458	M 10 x 1,5
DR-4459	M 8 x 1,25

VÁLVULAS EYECTORAS DE POLVO

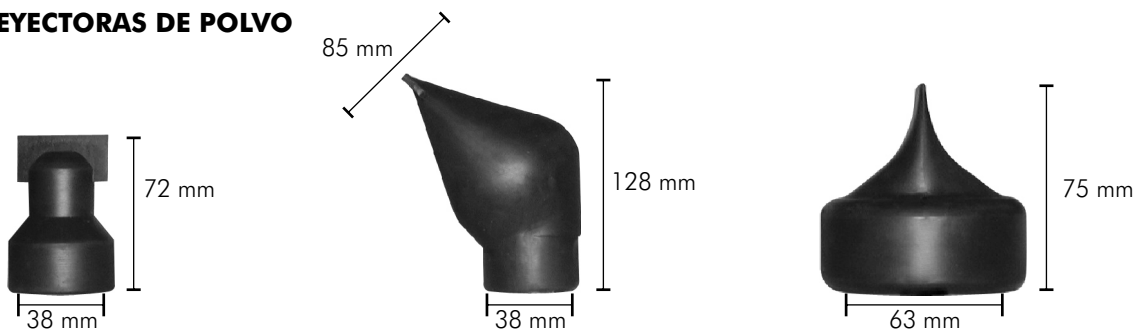

PARTE N° DG-4379	PARTE N° DG-4380	PARTE N° DG-4381
-------------------------	-------------------------	-------------------------

BUJES DE FORMA

PARTE N°	A	B	C	D
DG-4382	58	68	65	24
DG-4383	79	90	84	24

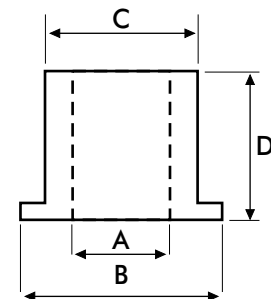

BUJES RECTOS

PARTE N°	A	B	C
DG-4384	60	71	35
DG-4385	80	88	35
DG-4386	95	105	35
DG-4387	76	90	35

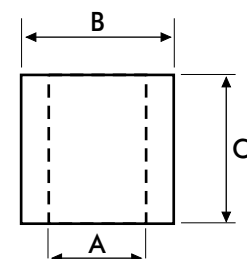

UNIONES

PARTE N°	A	B
DG-4331	46	89
DG-4332	62	94
DG-4333	75	92

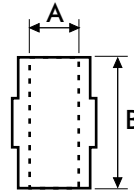

REDUCTORES

PARTE N°	A	B	C
DG-4334	51	63	106
DG-4335	63	70	122
DG-4336	63	76	122
DG-4498	70	82	90
DG-4337	76	102	110
DG-4338	102	130	140

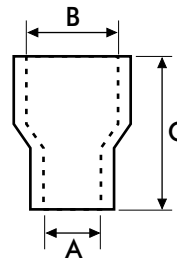

CODOS DE 90°

PARTE N°	A	B
DG-4339	50	50
DG-4340	63	85
DG-4549	70	70
DG-4341	76	92
DG-4342	80	92
DG-4343	102	97
DG-4345	132	118
DG-4346	152	127
DG-4413	90	95
DG-4419	127	118

CODOS 90° C/REDUCCIÓN

PARTE N°	A1	B1
DG-4501	70	60
DG-4414	76	63
DG-4415	102	76
DG-4416	102	82
DG-4417	133	102
DG-4418	152	140
DG-4472	178	152
DG-4492	82	63

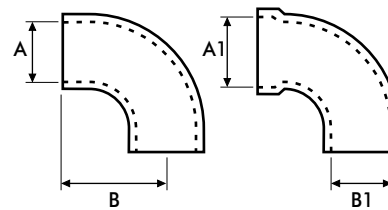

UNIONES

PARTE N°	A	B
DG-4351	63	63
DG-4352	76	76
DG-4353	82	76
DG-4354	76	58
DG-4355	102	76
DG-4356	110	102
DG-4357	130	102
DG-4358	80	76
DG-4404	70	60
DG-4412	133	102

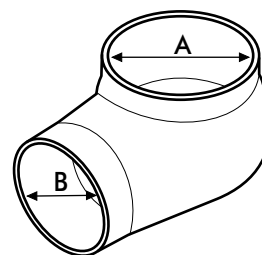



REFRIGERANTE/ANTICONGELANTE
LARGA VIDA (CONCENTRADO)

LANSSCOOL 2000
Long Life Coolant/Antifreeze

- para utilizar una concentración refrigerante la solución debe efectuarse al 30%, menos no se recomienda.
- para la máxima protección contra la congelación en áreas extremadamente frías utilizar una solución de 70% como máximo.

AGUA DESMINERALIZADA
Para Sistemas Refrigerantes

Ventajas

- No modifica las características del anticongelante
- Extiende la vida del refrigerante / anticongelante
- Mínimo desgaste / mantenimiento
- Protección y limpieza a temperaturas altas

Características

Color	2
Res. P/evap.	20 mg/Lt
Mat. Org.	Vestigios
CL (en Cl ₂)	0,05 mg/Lt
Nh ₃ (en N ₂)	0,2 mg/Lt
NO ₂ (en N ₂)	0,2 mg/Lt
NO ₃ (en N ₂)	0,2 mg/Lt
SO ₄ H ₂	0,2 mg/Lt
S H ₂	0,2 mg/Lt
Plomo, cobre, Cinc, Hierro, Manganeso	No contiene
Punto de ebullición	212°F / 100°C
Punto de congelación	32°F / 0°C

Atención: En su punto de congelación el volumen del agua se expande 9%.

TRATAMIENTO DEL SIST. ANTICONGELANTE
MAS COOLANT
Cooling System Treatment

Características

Punto de congelación	-34°F	-36,7°C
Punto de ebullición	265°F	129°C
pH		8,2
Reserva alcalina		6,1
% silicato		0

TRATAMIENTO DEL SIST. REFRIGERANTE

COOLMIX - I
Cooling System Treatment

Características

Punto de congelación	15°F	-9°C
Punto de ebullición	215°F	102°C
pH		8,2
Reserva alcalina		6,1
% silicato		0

PRODUCTO	PARTE N°				
	1 LITRO	5 LITROS	10 LITROS	100 LITROS	200 LITROS
AGUA DESMINERALIZADA	1000-01	1000-05	1000-10	1000-100	-
LANSS COOL 2000	2000-01	2000-05	2000-10	-	-
MAS COOLANT	-	3000-05	3000-10	3000-100	-
COOLMIX-1	-	4000-05	4000-10	4000-100	4000-200

Extender^{mas}[®]

**La mejor performance
en condiciones operativas
extremas**



- Mayor umbral de filtración
- Mayor Caudal
- Mayor durabilidad

- Alta capacidad en la retención de contaminantes
- Menor diferencial de presión
- Estabilidad estructural a altas Temperaturas del fluido

APLICACIONES

- Sistemas hidráulicos De media y alta presión
- Sistemas de transmisión Powershift
- Circuitos piloto
- Sistemas de carga hidrostática
- Sistemas de combustible diesel
- Circuito de aceite de motor

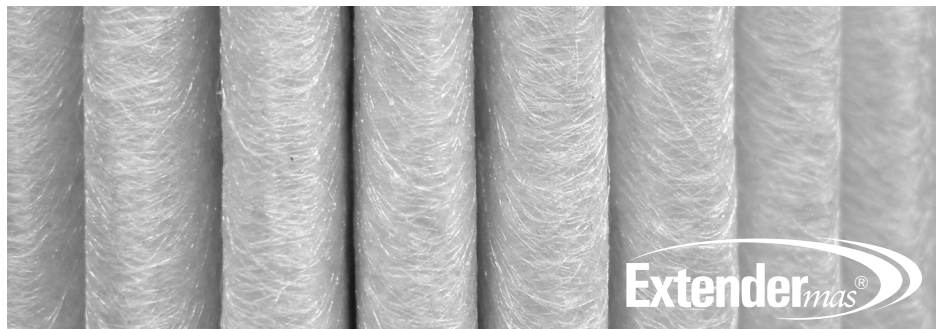
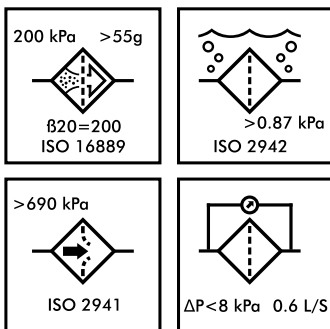

UNIPLUG® Línea de filtros para combustible de cierre a presión



Aplicaciones:
AGCO - CASE - CATERPILLAR
FORD - IVECO - JCB - JOHN DEERE
MASSEY FERGUSON - MITSUBISHI
NEW HOLLAND - PERKINS - SULLAIR
SISU DIESEL - VALTRA - VOLVO

Pruebas de laboratorio según Normas SAE J905.

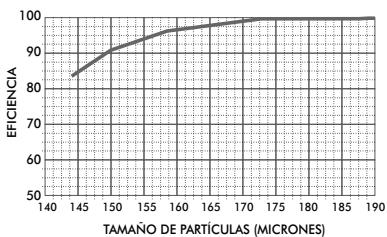
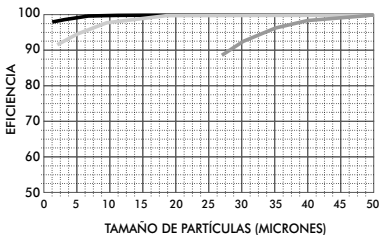

- Retención de partículas de 2 micrones
- Retención de partículas de 5 micrones
- Retención de partículas de 30 micrones
- Retención de partículas de 150 micrones

Ventajas

- 1 - Se incorpora un diseño de doble sello flexible para efectuar una mayor seguridad del mismo.
- 2 - Carcasa totalmente metálica, brinda una alta resistencia contra roturas por impulsos.
- 3 - Válvula de drenaje de apertura fácil, libre salida y autoventeo.
- 4 - Las claves de encastre: se han eliminado para un uso universal sobre los cabezales de montaje.
- 5 - Sello interior puede ser de (goma) como de nylon, según el modelo del filtro, este debe efectuar un cierre perfectamente hermético.
- 6 - Los medios filtrantes altamente eficaces Hidroblok® de tecnología LANSS, repele el agua y retiene todo tipo de contaminante sólido.
- 7 - Junta, para el recambio en la tuerca de cierre. (Opcional código N° DG-4475).
- 8 - La eficiencia de los filtros **UNIPLUG**® cubre el requerimiento que va de 2 a 150 micrones. Hay un filtro para cada necesidad.

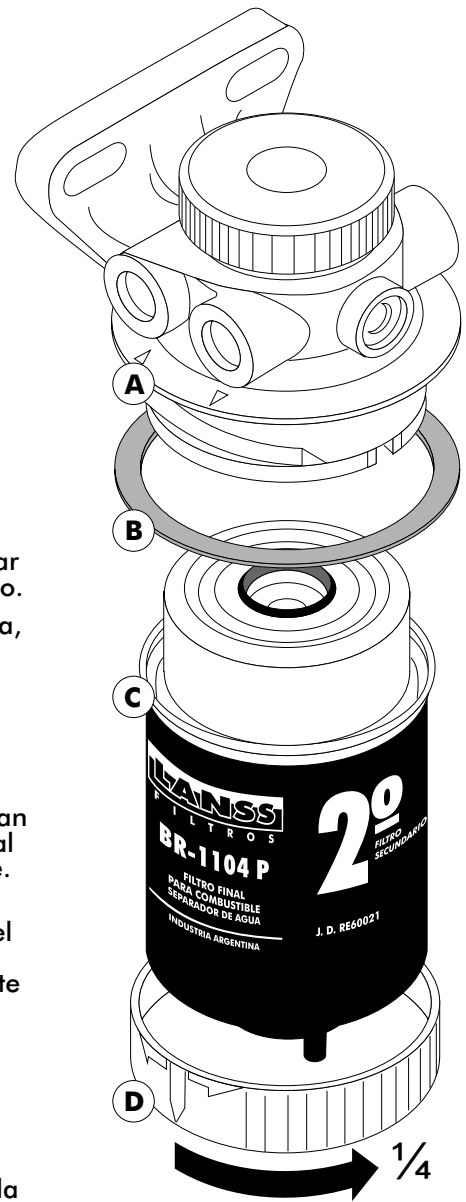

- A** Cabezal de aluminio
- B** Junta LANSS N° DG-4475
- C** Filtro LANSS - UNIPLUG
- D** Tuerca de cierre

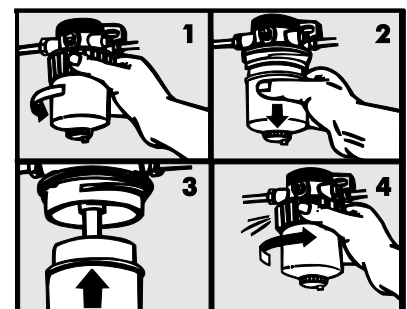
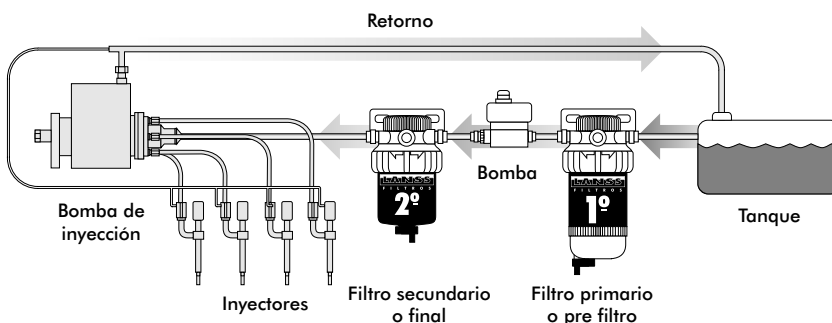

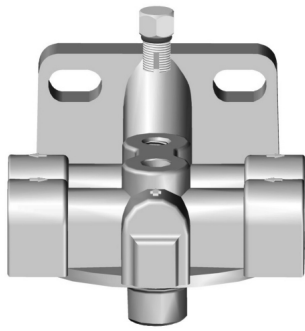

TAPÓN DE VENTEO



CABEZAL DE ALUMINIO
CB-5018
(Rosca 1" x 14)



ELEMENTO FILTRANTE
(Junta diám. 110-93)
• **BR-45H (*1)**
• **BR-60H (*2)**
• **BR-90H (*3)**
• **BR-120H (*4)**
• **BR-1200H (*5)**



ELEMENTO FILTRANTE
(Junta diám. 90-76,5)
• **BR-1145H (*1)**
• **BR-1146H (*2)**
• **BR-1147H (*3)**
• **BR-1148H (*4)**
• **BR-1149H (*5)**

Línea Mercedes Benz
CABEZAL PORTA FILTRO
CB-5019
ELEMENTO FILTRANTE
(Junta diám. 110-93
Rosca 1" x 12)
• **BR-90HM**
• **BR-120HM**
• **BR-1201HM**

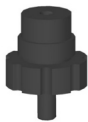

O RING

RECIPIENTE COLECTOR DE AGUA TRANSPARENTE
• **DR-4465** (con tapón sensor)
• **DR-4473** (sin tapón sensor)

RECIPIENTE COLECTOR DE AGUA DE ALUMINIO
• **DR-4476**



PURGADOR DE AGUA
• **DR-4523**



TAPÓN PARA SENSOR DE AGUA
• **DR-4464**

SERIE L1

EQUIPOS SEPARADORES DE AGUA

L1-45 L1-60 L1-90 L1-120 L1-1200

L1-1145 L1-1146 L1-1147 L1-1148 L1-1149

Los filtros para combustible separadores de agua LANSS® Serie L1, son de desempeño versátil en las condiciones severas de trabajo. Los Filtros LANSS con tecnología aplicada HIDROBLOK® logra una excelente separación de agua y retención de partículas sólidas. Son aplicados a una amplia gama de maquinarias y motores evitando el desgaste del sistema de combustible. Cumplen las especificaciones más exigentes.

SAE J905 Restricción del fluido de combustible

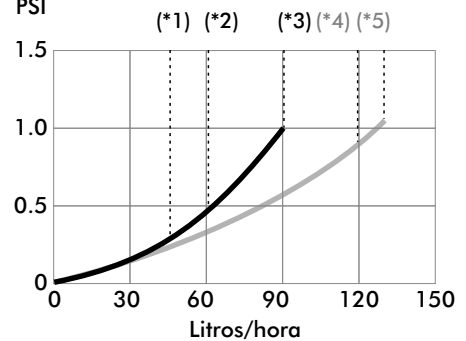

SAE J905 Capacidad

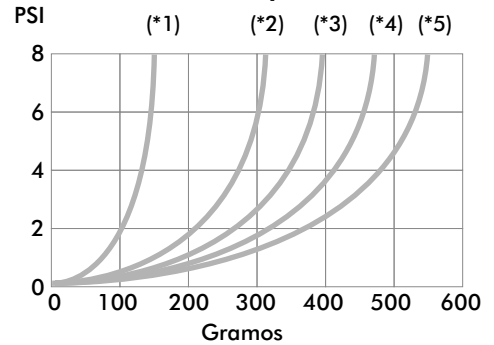

INSTALACIÓN

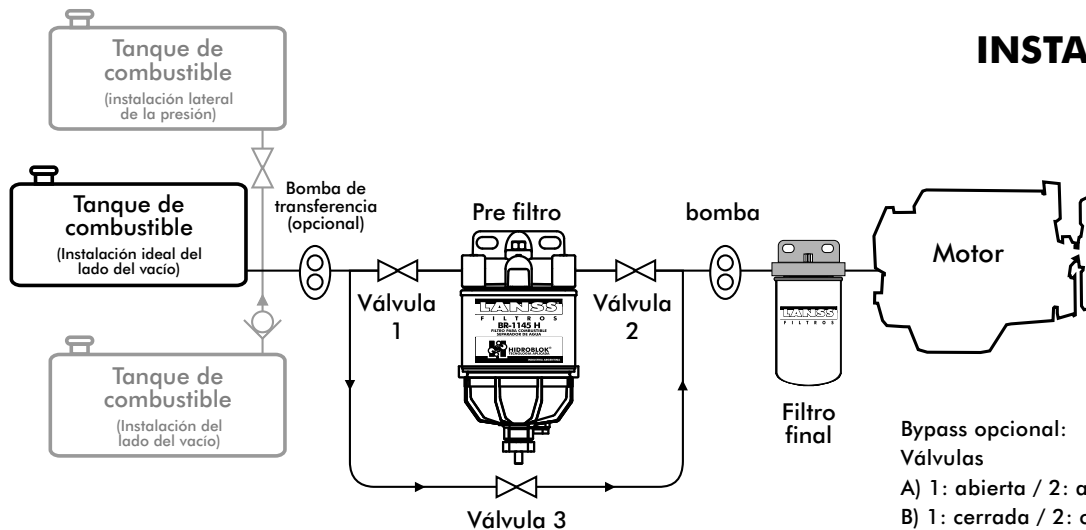

Bypass opcional:
Válvulas

A) 1: abierta / 2: abierta / 3: cerrada
B) 1: cerrada / 2: cerrada / 3: abierta

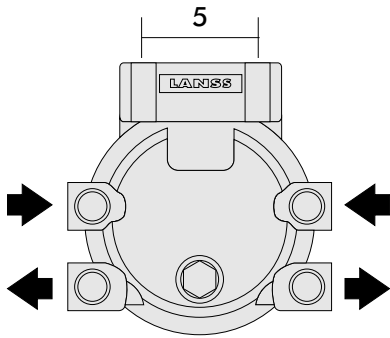

FLUJO INVERSO

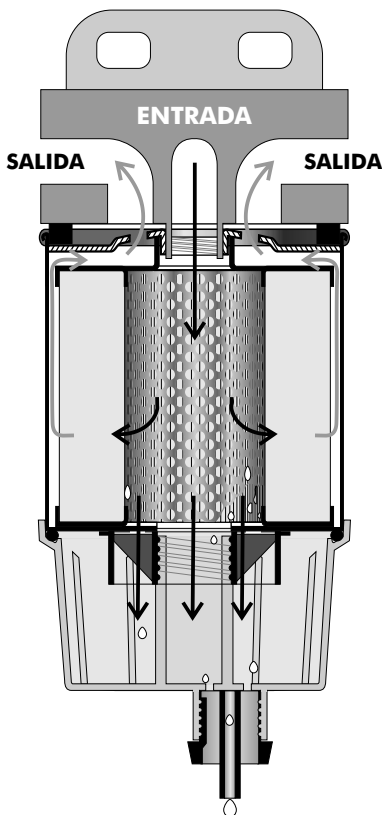

CABEZAL DE ALUMINIO
CB-5016
Rosca 1" x 14
(C/2 tapones).

ELEMENTO FILTRANTE
(Junta diám. 90-76)
• **BR-24H (*1)**
• **BR-26H (*2)**
• **BR-28H (*3)**
• **BR-1119H (*4)**

O-RING

RECIPIENTE COLECTOR DE AGUA TRANSPARENTE
• **DR-4455** (con tapón sensor)

PURGADOR DE AGUA
• **DR-4523**

Para las aplicaciones de equipos náuticos se recomienda el uso de recipientes de protección metálicos.

Accesorios opcionales

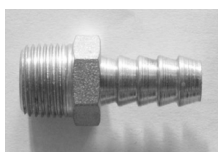

DR-4514
CONECTOR PARA MAGUERA Ø 10mm
ROSCA M14 x 1,50 x 36



DR-4518
TAPÓN Y ARANDELA PARA CABEZALES
ROSCA M14 x 1,50 x 20



DR-4534
BULÓN PERFORADO PARA UNIÓN ORIENTABLE Ø 14
ROSCA M14 x 1,50 x 34mm.



DR-4529
UNIÓN ORIENTABLE MAGUERA Ø 10mm
Ø int. 14

SERIE L2 EQUIPOS SEPARADORES DE AGUA
L2-24 L2-26 L2-28 L2-1119

Los motores de última generación requieren un combustible libre de contaminantes. La condensación que se genera en los tanques, es un problema recurrente hasta en los combustibles de máxima calidad. El agua produce el deterioro de partes del motor desencadenando potenciales averías.

Los filtros para combustible separadores de agua LANSS® Serie L2, son de desempeño versátil en las condiciones severas de trabajo. Los Filtros LANSS con tecnología aplicada HIDROBLOK® logra una excelente separación de agua y retención de partículas sólidas. Son aplicados a una amplia gama de equipos náuticos, camiones semi pesados y maquinarias para la construcción evitando el desgaste del sistema de combustible.

Filtros que cumplen con las especificaciones más exigentes.



- El flujo del gasoil en los elementos es de adentro hacia afuera.
- La eficiencia de los elementos es de 94% para partículas de 12 micrones.
- Instalar en succión, entre el tanque de combustible y la bomba de transferencia.

SERIE L EQUIPOS SEPARADORES DE AGUA

Protector[®]

MODELO	CAUDAL MÁXIMO	ELEMENTO FILTRANTE	APLICACIONES
L -900 H	340 L x h.	PF-2040 N	Motores hasta 250 HP Tractores - Generadores - Equipos viales Equipos marinos - Compresores - Cosechadoras
L -1000 H	680 L x h.	PF-2020 N	Motores hasta 500 HP Tractores - Generadores - Equipos viales Equipos marinos - Compresores - Cosechadoras

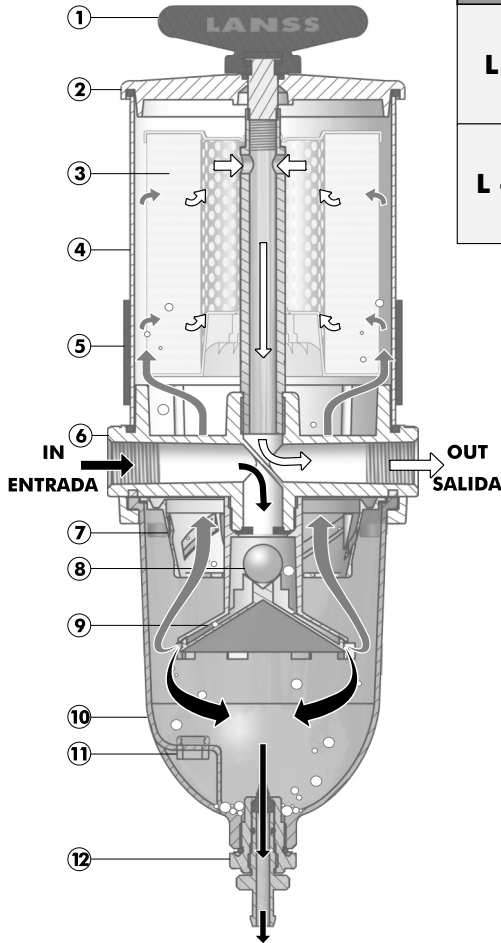

- 1 - Soporte manual de cierre
- 2 - Tapa servicio
- 3 - Elemento HIDROBLOK[®]
- 4 - Cuerpo
- 5 - Abrazaderas soporte
- 6 - Base
- 7 - Deflector coalescente
- 8 - Válvula de retención
- 9 - Depresor cónico
- 10 - Recipiente transparente
- 11 - Tapón entrada sensor p/agua
- 12 - Válvula de drenaje

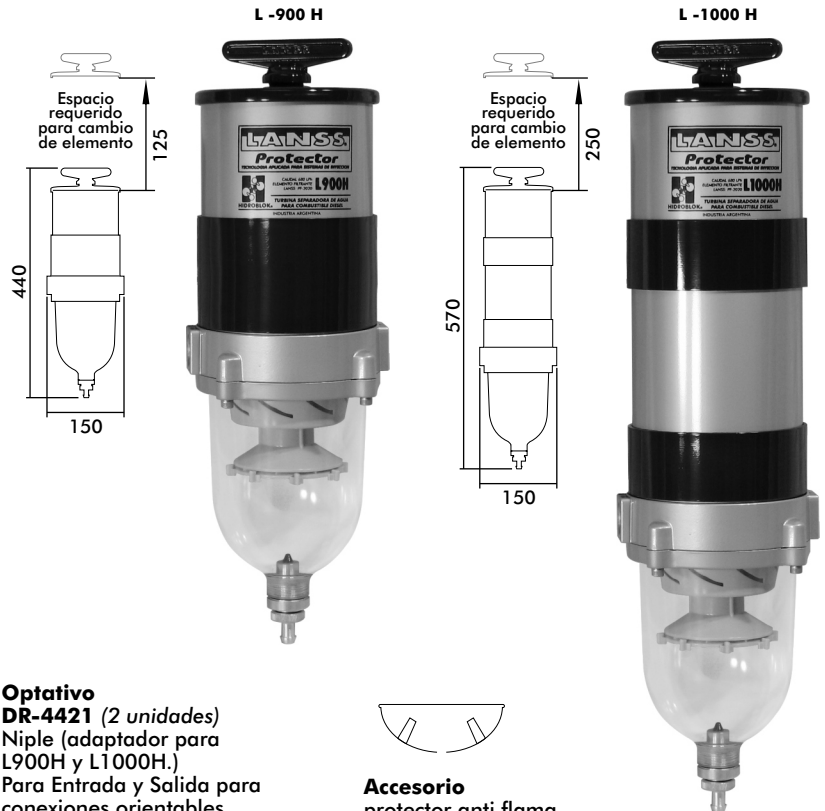

Optativo
DR-4421 (2 unidades)
Niple (adaptador para L900H y L1000H.)
Para Entrada y Salida para conexiones orientables.
Rosca ext. 7/8 x 14 UNF
Rosca int. M 14 x 1,5.

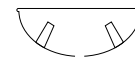

Accesorio
protector anti flama
acero inoxidable
DR-4420
(Aplicación marino)



DR-4491 (2 unidades)
Rosca 7/8 x 14 UNF
asiento JIC 7/8 x 14 UNF

PROTECCIÓN CONTRA GOLPES



Soporte con protección
DR-4494
(para L900H)

DR-4493
(para L1000H)



EQUIPO	Elementos HIDROBLOK [®]	Distintos niveles de filtrado de acuerdo al requerimiento de uso.
L 900 H	PF 2040 N/2	2 micrones - Tapa negra
	PF 2040 N/4	4 micrones - Tapa marrón
	PF 2040 N/12	12 micrones - Tapa azul
	PF 2040 N/30	30 micrones - Tapa roja
L 1000 H	PF 2020 N/2	2 micrones - Tapa negra
	PF 2020 N/4	4 micrones - Tapa marrón
	PF 2020 N/12	12 micrones - Tapa azul
	PF 2020 N/30	30 micrones - Tapa roja

Equipo L1000H doble para motores industriales/marinos de hasta 1000 HP

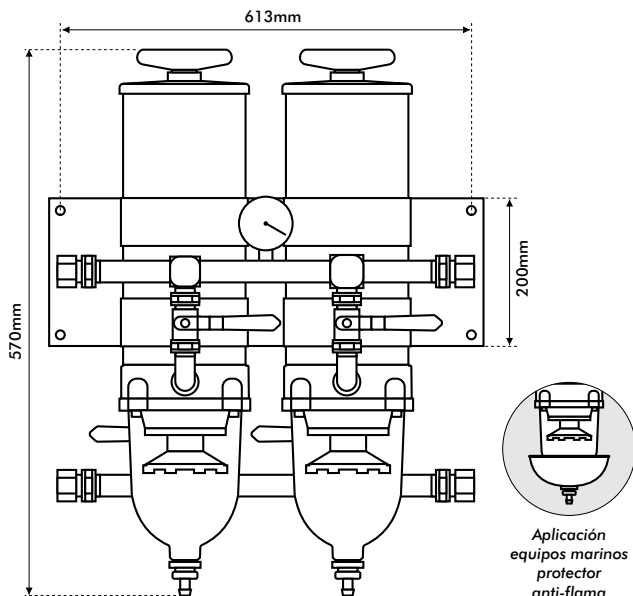

Conexión de Entrada-Salida 1/2
 Aplicación equipo marino: con protección anti-flama
 Potencia Máxima 1000 HP
 Caudal máximo 1360 l/h
 Elemento filtrante Hidroblok®: PF-2020N/12 (12 micrones)
 Opcionales: PF-2020N/2 (2 micrones)
 PF-2020N/4 (4 micrones)
 PF-2020N/30 (30 micrones)

Equipos L1000H en paralelo para motores marinos de hasta 2100 HP

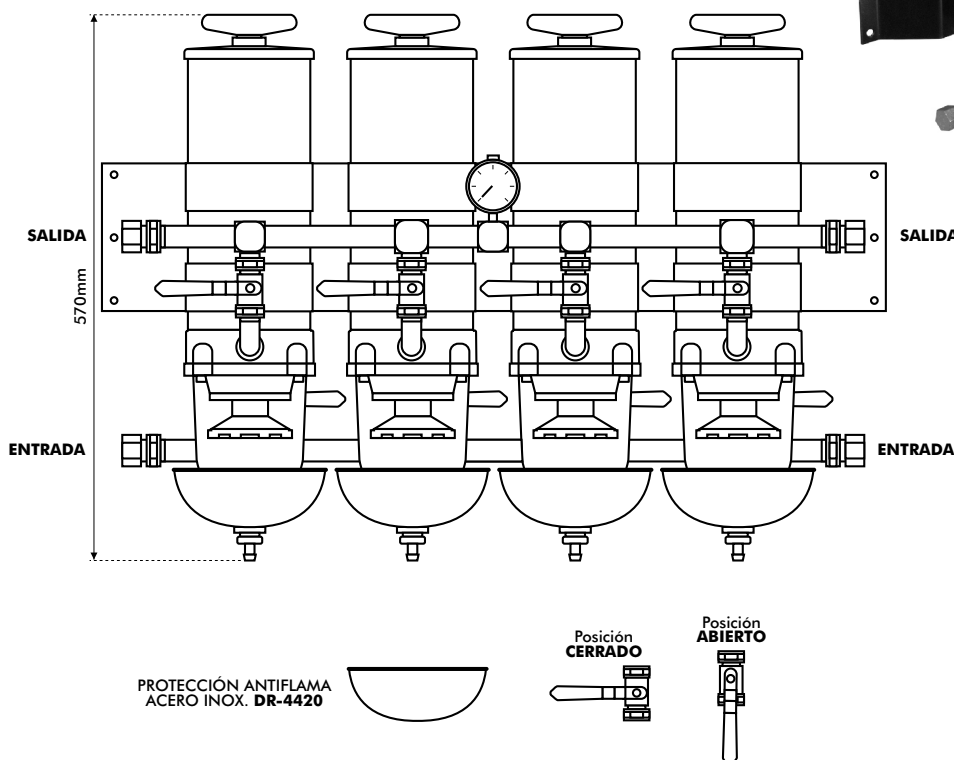

- Equipos separador de agua y partículas de 4 unidades L1000H conectados en paralelo. Unidos por un conector común de 3/4" (Entrada-Salida).

- Cada unidad posee dos válvulas para realizar el mantenimiento de los elementos.

- El equipo Protector® L1000H porta un elemento filtrante PF-2020N/12 (eficiencia 12 micrones), opcional: PF-2020N/4 (eficiencia 4 micrones) ó PF-2020N/30 (eficiencia 30 micrones).

- Incluye manómetro y protección antiflama garantizando su óptimo funcionamiento y seguridad.



MODELO	CAUDAL MÁXIMO	ELEMENTO FILTRANTE	APLICACIONES
LCS -2000 EQUIPO DISCONTINUO	4200 L x h.	PF-560 SC	Surtidor de Servicio Sistemas de Reserva
LCS -2001	4200 L x h.	PF-560/1 SC	Sistema de Transvase

PF-560/1 SC



FILTRO HIDROBLOK®
PF-560/1 SC de
Tecnología LANSS®
Retención efectiva 99,5%.
Filtrado en doble etapa:
Elemento coalescedor:
15 micrones.
Elemento final (separador):
6 micrones.

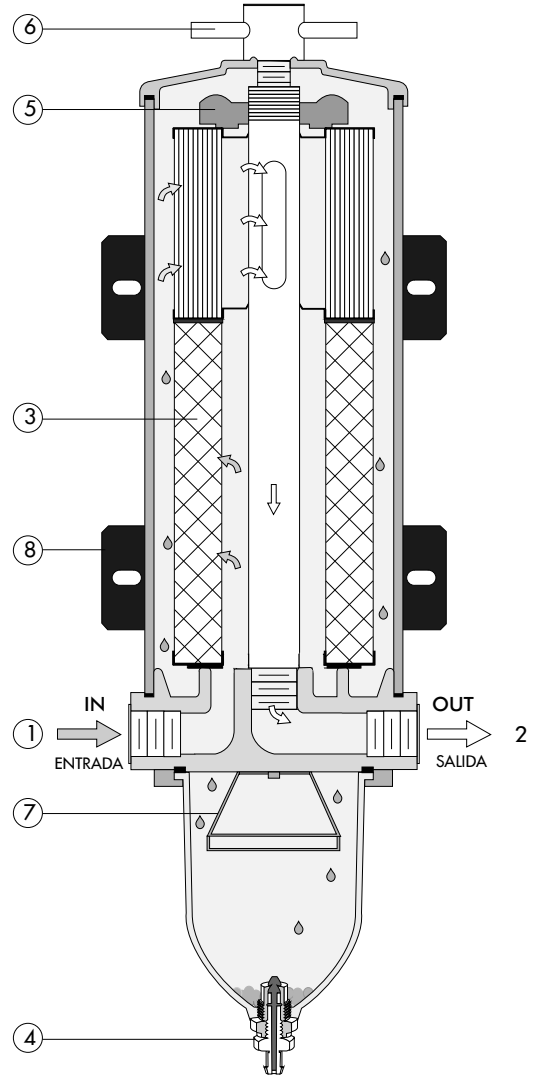

Instalación

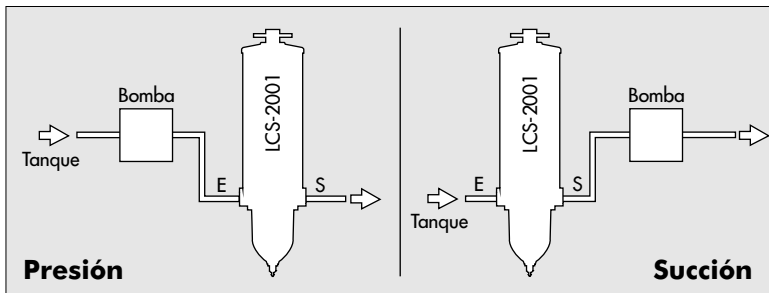

1. Entrada (IN)
2. Salida (OUT)
3. Elemento filtrante Hidroblok®
4. Drenaje de agua
5. Tuerca de sellado del filtro
6. Manija tapa de servicio
7. Deflector de agua
8. Banda de montaje

RECOMENDACIÓN:
TENGA UN REEMPLAZO EXTRA DEL ELEMENTO
PF-560/1 SC YA QUE UN TANQUE LLENO O
CON EXCESIVA SUCIEDAD EN EL COMBUSTIBLE
PUEDE RAPIDAMENTE SATURAR EL FILTRO

Protector®

Retención de contaminantes:

- agua
- hongos - microorganismos
- óxido de hierro
- partículas metálicas - carbonosas
- cristales de sílice
- micro fibras

EMS

001
002



Detalles técnicos*

FILTRO CONJUNTO	LCS-2001
ANCHO / ALTO	73 cm / 110 cm
BOMBA	CENTRIFUGA
CAUDAL	4200 Litros/hora
FILTRO HIDROBLOK®	PF-560/1 SC
ORIFICIO ENTRADA-SALIDA	1" BSP
PRESIÓN MÁXIMA	2,2 kg/cm ² - 31,28 PSI
TEMPERATURA DE FUNCIONAMIENTO	-40° C / 110°C
▶ EMS 001 - MOTOR ELÉCTRICO	12V
▶ EMS 002 - MOTOR ELÉCTRICO	220V

SISTEMA DE FILTRADO CONTINUO

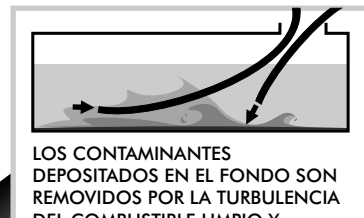
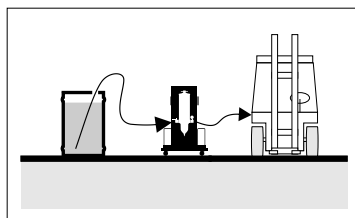
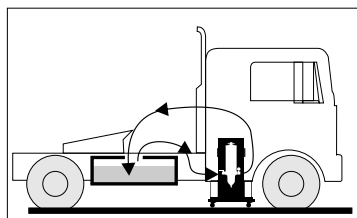
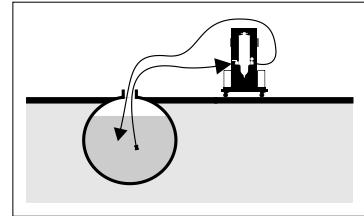
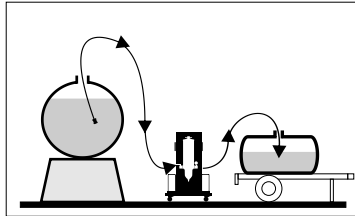
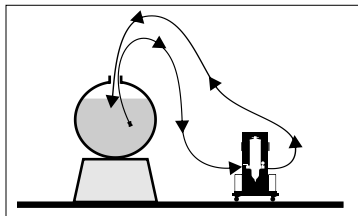

LOS CONTAMINANTES DEPOSITADOS EN EL FONDO SON REMOVIDOS POR LA TURBULENCIA DEL COMBUSTIBLE LIMPIO Y ASPIRADOS PARA SU SEPARACIÓN.

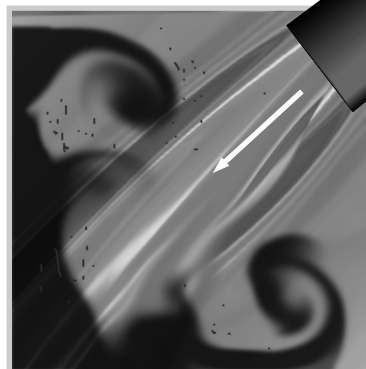
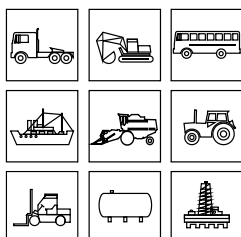

IMPORTANTE:
CUANDO SE REALICE LIMPIEZA BAJO Y SOBRE EL NIVEL DE LA UNIDAD MÓVIL EMS-001 / 002, DEBE INCORPORAR EN EL EXTREMO DE LA MANGUERA DE ENTRADA, UNA VÁLVULA DE RETENCIÓN. Y COMPLETAR EL EQUIPO CON COMBUSTIBLE.

Protector® GC08

**Equipo para Combustible
Coalescedor/Separador
de Agua para Gran Caudal**

FILTRACIÓN EFECTIVA CONTRA:

- AGUA
- AZUFRE
- PARAFINA
- MICROFIBRAS
- ÓXIDO DE HIERRO
- HONGOS
- MICROORGANISMOS
- PARTÍCULAS METÁLICAS-CARBONOSAS
- CRISTALES DE SÍLICE

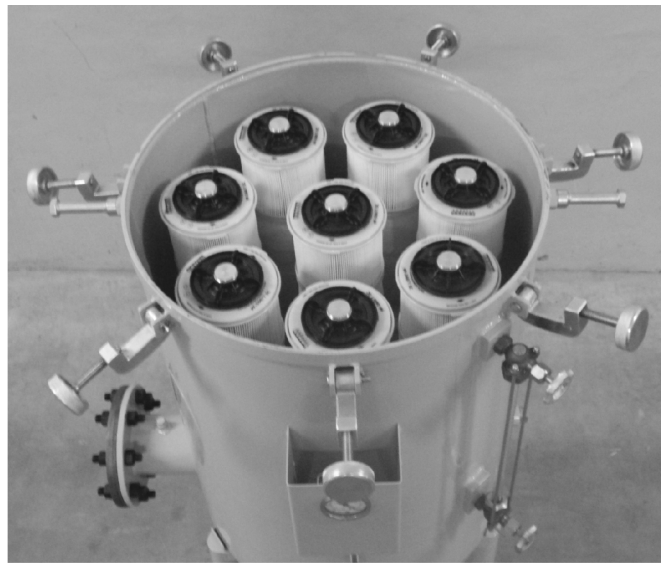

El equipo purificador de combustible GC08 de LANSS, de gran versatilidad, economía y fácil mantenimiento para grandes caudales de combustible. La estructura robusta y la articulación de elementos para una filtración simultánea en dos etapas coalescente y separadora de agua, hacen de este producto un equipo indispensable para el abastecimiento de combustibles almacenados o trasvasado para grandes volúmenes.

El uso de 8 unidades independientes, mejora el volumen de fluido a filtrar y reduce los costos de mantenimiento.

Filtra 31.200 L/H



Unidades de filtrado para grandes tanques de almacenamiento, sistemas de reserva o de servicio diario. Efectivos contra las impurezas del aceite y combustible en equipos donde son requeridos por su gran caudal.



Las unidades de filtrado CAPTOR® para fluidos, separan y eliminan los contaminantes sólidos y líquidos. La línea CAPTOR® es ideal para la purificación de sustancias basadas en petróleo (aceites hidráulicos, aceites de engranajes, aceite lubricantes y combustibles (gasoil - fuel oil - etc.)), asegurando un fluido limpio y libre de toda contaminación (óxido de hierro, cristales de sílice, materia carbonosa, fibras textiles y partículas metálicas).

Especificaciones

Generalmente las unidades de filtrado CAPTOR® pueden bombear y filtrar aceites - combustibles con densidades medias de 647 cst. (Centistoke) con una gravedad especificada de 0,85.

Con una previa clasificación del tipo de fluidos a filtrar se empleará y adaptará especialmente la unidad para cada requerimiento.

Los sistemas de filtrado CAPTOR® se encuentran equipados con un filtro en la primer etapa (entrada)

que barre con contaminantes de 100-60 micrones y un filtro en la etapa secundaria (salida) para un filtrado intensivo de 25-10-5 micrones.

En esta etapa se encuentra equipado con un indicador de presión para establecer la saturación del filtro. La unidad con doble etapa filtrante asegura a la bomba como así también a las partes críticas del sistema hidráulico un mayor rendimiento con una mayor eficacia.

La manguera de conexión de entrada y salida (1" ó 3/4") llevan incorporadas en cada extremo tapas antiderrame.

En la manguera de entrada se incluye para su conexión un tubo rígido para el fácil manejo de la absorción de los fluidos entrantes.

El sistema Motor-Bomba es una unidad monoblock compacta asegurando un excelente rendimiento. En la parte inferior de la unidad cuenta con una bandeja de purgado para mantener la zona de trabajo limpia y segura evitando derrames cuando se efectúa el servicio de mantenimiento.

Detalles técnicos*

FLUIDO A FILTRAR (ÍNDICE DE VISCOSIDAD)	60 - 200
CAPACIDAD DE FLUJO	360 - 2500 L/HORA
BOMBA	ROTATIVA ASPIRANTE VOLUMETRICA
CAUDAL	1400 / 2700 / 3800 Litros/hora
FILTRO PRIMARIO	MALLA INOX. (S/REQ.)
FILTRO SECUNDARIO	CELULOSA - FIBRA DE VIDRIO (S/REQ.)
PRESIÓN MÁXIMA	3,5 kg/cm ² - 49,77 PSI
TEMPERATURA DE FUNCIONAMIENTO	-40° C / 107°C
MOTOR ELÉCTRICO	380 - 220V / 1500 / 2800 RPM

*Fabricados según especificaciones y requerimientos.

Kit DK-4490 protección extra para el sistema common rail de **TOYOTA Hilux**

El Kit DR-4490 de LANSS de diseño innovador, sirve como filtro primario separador de agua, entregándole al filtro original un combustible diesel pre depurado, aumentando el rendimiento general de las camionetas TOYOTA. Usa repuesto filtro **LANSS BR-1178**.



Las camionetas TOYOTA están equipadas con filtros de combustible diseñados para funcionar bajo determina-dos parámetros de calidad de combustible diesel.

En nuestro país, la calidad del combustible no se encuentran dentro de los parámetros requeridos para los nuevos motores (reglamentaciones vigentes tanto de Europa como de los EEUU). Por lo tanto Filtros LANSS recomienda tomar las precauciones sobre la filtración del fluido, para proteger los motores con sistema common rail, evitando daños en los componentes de inyección de alta precisión.

Instalación:

- A - Soporte porta cabezal.
- B - Filtro LANSS BR-1178.
- C - Mangueras: Tanque-Filtro primario / Filtro primario-Filtro secundario.
- D - Filtro original.

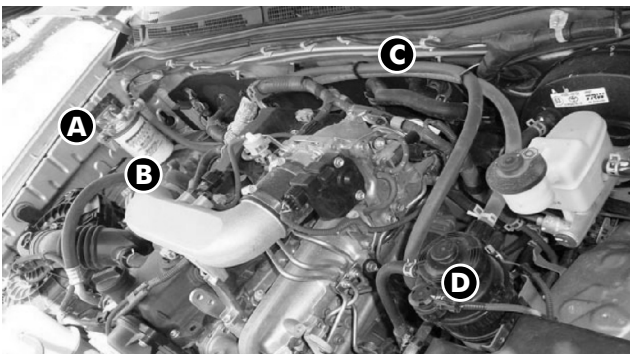

Kit DK-4496 protección extra para el sistema common rail de **FORD Ranger**

- Prolonga la vida del filtro de combustible final (original R-FG-92).
- Protege el filtro original y mejora su rendimiento.
- Incrementa el rendimiento del motor.
- Protege todos los componentes del sistema de inyección (common rail).

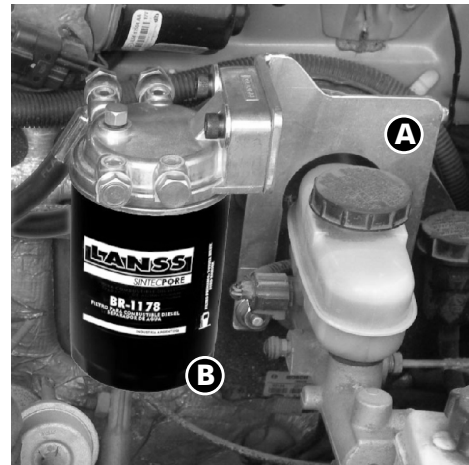

Instalación:

- A - Soporte porta cabezal.
- B - Filtro LANSS BR-1178.
- C - Mangueras: Tanque-Filtro primario / Filtro primario-Filtro secundario.
- D - Filtro original.

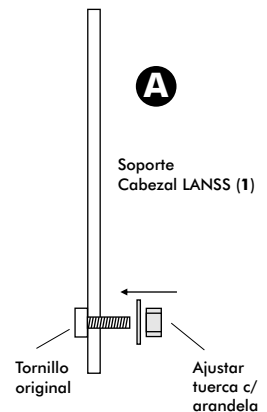

• **MAYOR PROTECCIÓN**

• **MAYOR RENDIMIENTO**

Realice el cambio del filtro LANSS cuando realiza el recambio del filtro final (según manual del usuario).

Kit DK-4450

Kit DK-4450 de alto rendimiento con tecnología LANSS®, para la línea de camiones VOLKSWAGEN generación 2003 y FORD Cargo.

Ventajas:

- Fácil instalación.
- Auto-limpiante, no requiere mantenimiento.
- Protege la vida de su motor.
- Elimina el 85% de los contaminantes del aire, antes de alcanzar a los elementos de aire.
- Prolonga el mantenimiento, postergando el recambio de los elementos filtrantes.
- Optimiza el consumo de combustible.
- Evita el ingreso de agua al sistema de filtrado en seco.



Vista superior
(SENTIDO EXPULSION DE CONTAMINANTES)

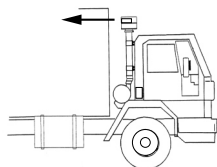
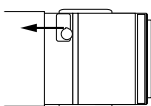

DK-4504

KIT PARA TRACTORES
HANOMAG 250A, 350A y 500A



LA MEJOR PROTECCIÓN PARA MOTORES DIESEL:

- Mayor vida útil de los elementos de aire
- Menor consumo de combustible
- AHORRO de costos de mantenimiento

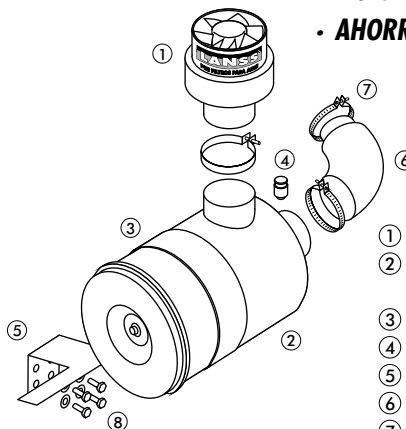

- 1 PREFILTRO MOD. TJ-100 C/ABRAZADERA
- 2 CARCAZA METÁLICA CON FILTROS 1º: EF-982 | 2º EF-983
- 3 BANDA DE MONTAJE
- 4 INDICADOR DE RESTRICCIÓN XI-2250
- 5 SOPORTE DE CARCAZA
- 6 CODO ADAPTADOR
- 7 ABRAZADERAS
- 8 4 TORNILLO M8 x 1,25 x 25 mm
4 ARANDELAS PLANAS



Reforma LANSS

- Prefiltro centrífugo de aire
- Filtros primario y secundario de mayor capacidad.
- Indicador de restricción



Protección para un Mundo en Movimiento

Ucrania 459 - (B1822CSI) - V. Alsina -
Pcia. de Buenos Aires - Argentina -
Planta Industrial: Rep. Argentina
2237 - V. Alsina
Tel. Fax: 0054 11 4208 7311 | 4228
4681 - filtros@lanss.com.ar -
www.lanss.com.ar